



# AVENTOS

An inspiring range of lift systems





# Ease of motion – multitude of options

The AVENTOS lift system brings ease of motion to the wall cabinet. Even large and heavy lift systems can be opened with the utmost ease. What makes AVENTOS especially practical is that it offers the furniture user full freedom of movement and provides the necessary cabinet access at all times. Your customers will be inspired.

## Contents

- 4 Lift system range
- 5 Ideas for practical kitchens
- 6 The lift system programme
- 8 Motion technologies
- 10 Top quality
- 12 Assembly
- 14 Frequently asked questions
- 16 Design
- 18 AVENTOS HF
- 34 AVENTOS HS
- 42 AVENTOS HL
- 50 AVENTOS HK
- 64 AVENTOS HK-S
- 72 Blum transformer and accessories
- 74 SERVO-DRIVE for AVENTOS functions
- 80 Blum

# The lift system programme

## They fold, lift and swing up and over with fascinating ease

AVENTOS is the ideal solution for any wall cabinet. Whether it is used in the kitchen or living area, whether there is lots of space available or only a little and whether it is used with small or large fronts, one thing never changes: the supreme ease of motion. Thanks to integrated BLUMOTION, lift systems always close silently and effortlessly. Combined with SERVO-DRIVE, lift systems will open with a light touch and close automatically with a press of a button.

In addition to their proven stability and elegant design AVENTOS lift systems offer a complete solution for all round high level movement.



### Bi-fold lift system AVENTOS HF

- Ideal for high wall cabinets
- Handle is easy to reach, even when the lift system is open
- Takes up minimal space even with large cabinet heights, thanks to the two-part front
- Can be used with fronts of different heights
- Variable stop



### Up & over lift system AVENTOS HS

- Ideal for large, one-part fronts
- Minimal space required thanks to swivel motion
- Can be combined with cornice or crown moulding
- No hinges required
- Variable stop



### Lift up AVENTOS HL

- Ideal for tall or wall cabinets with fronts above or for recessed cabinets.
- Suitable for smaller, one-piece and even low fronts
- Easy access to storage items
- No hinges required
- Variable stop



### Stay lift AVENTOS HK

- Ideal for small and medium wall cabinets
- The space requirement above cabinet is low thanks to the lift system motion
- No hinges required
- Variable stop



### Small stay lift AVENTOS HK-S

- Perfect for small cabinets, e.g. over refrigerators or larder units
- Harmonious proportions
- No hinges required
- Variable stop

# DYNAMIC SPACE



Ideas from Blum  
for practical kitchens

## DYNAMIC SPACE – Ideas from Blum for practical kitchens

Good workflows, enough storage space and top quality motion. For Blum, workflow, space and motion are the three essential features of a practical kitchen. With DYNAMIC SPACE, we offer helpful ideas, suggestions and solutions so that today's kitchens don't just look great, but are practical as well.

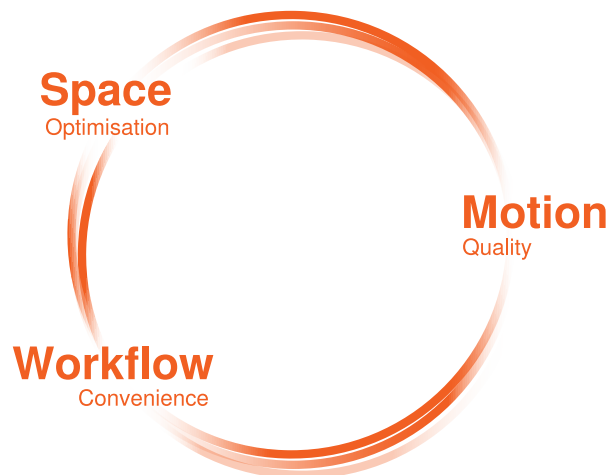

### Workflow – Easy access

With AVENTOS, the front moves up, taking it right away from the work area. This makes the cabinet contents easy to access at all times. If the cabinet is placed near the dishwasher, clean glasses can be put back in their rightful place at lightning speed.

### Space – Fits in with storage space requirements

Wall cabinets with lift systems are flexible with regard to size. The optimum size depends on your room layout, your individual storage space requirements and your aesthetic preferences. Depending on the lift system type, heights of approx. 185 mm to 1040 mm are possible, coupled with widths ranging from 300 mm to 1800 mm.

### Motion – New effortless for lift systems

Even heavy and wide fronts have a feather-light glide. Regardless of the force applied, all AVENTOS lift systems always close silently and effortlessly – thanks to BLUMOTION. With SERVO-DRIVE, the electrical motion support system, lift systems open with just a light touch and close at the touch of an easily accessible switch.

# The lift system programme

## Everything at a glance

The graphic below shows how the five fittings from the AVENTOS range can be used in a common kitchen system.

AVENTOS HL AVENTOS HL AVENTOS HF AVENTOS HS AVENTOS HS AVENTOS HF AVENTOS HS AVENTOS HS AVENTOS HK AVENTOS  
 AVENTOS HK AVENTOS HL AVENTOS HL HK-S  
 AVENTOS HK-S AVENTOS HL AVENTOS HL  
 AVENTOS HK AVENTOS HK

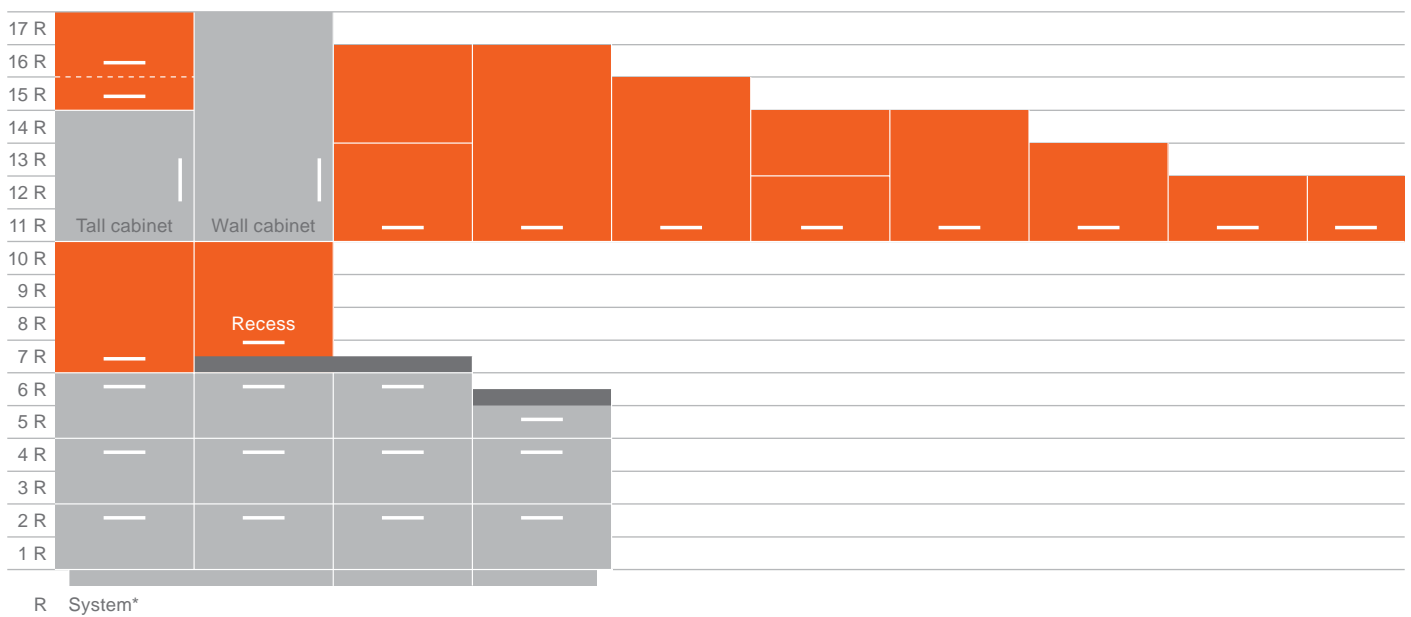

\* AVENTOS is flexible enough to be used in wall cabinets using 4-tier systems in addition to the 6-tier system shown above.

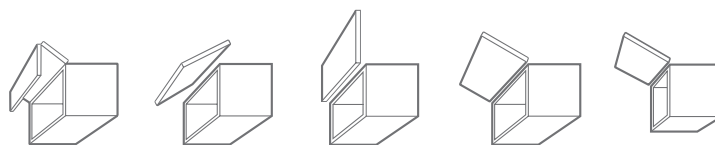

HF HS HL HK HK-S

**Area of application**

High wall cabinets	■	■			
Medium wall cabinets	■	■	■	■	
Low wall cabinets			■	■	■
Tall cabinets			■	■	■

**Room planning**

Min. top space requirement	■	■		■	■
----------------------------	---	---	--	---	---

**Design**

Single front		■	■	■	■
Two-part front	■				
Can be combined with cornice or crown moulding	■	■	■	■	■
Cabinet height dimensions in mm	480–1040	350–800	300–580	up to 600 <sup>1</sup>	up to 400
Cabinet width dimensions in mm	up to 1800	up to 1800	up to 1800	up to 1800	up to 1800 <sup>2</sup>

**Ergonomics**

Handles within easy reach	■	■	■	(■)	(■)
Easy access to cabinet interior	■	■	■	■	■

**Motion technologies**

BLUMOTION	■	■	■	■	■
SERVO-DRIVE	■	■	■	■	
TIP-ON				■ <sup>3</sup>	

<sup>1</sup> For ergonomic reasons, we recommend a maximum cabinet height of 600 mm. However, higher lift systems can also be implemented subject to the power factor limits (see page 54).

<sup>2</sup> Depending on the power factor

<sup>3</sup> Cannot be combined with BLUMOTION

# Fascinating ease of motion for lift systems

With its innovative motion technologies, Blum not only makes opening and closing lift systems easier – it turns the process into an experience.



## BLUMOTION

### BLUMOTION

#### Soft and effortless closing

BLUMOTION is synonymous with fascinating quality of motion. Allow your customers to see for themselves – they will be inspired

Compatible with



## SERVO-DRIVE

### SERVO-DRIVE

#### Unsurpassed ease of use

A single touch suffices and the lift system opens as if by magic. To close, simply press the easy-to-access switch on the inside of the cabinet.



## TIP-ON

### TIP-ON

#### Simply press the lift system and it opens

TIP-ON for AVENTOS HK our mechanical opening support system, now makes handle-less fronts easy and comfortable to open.





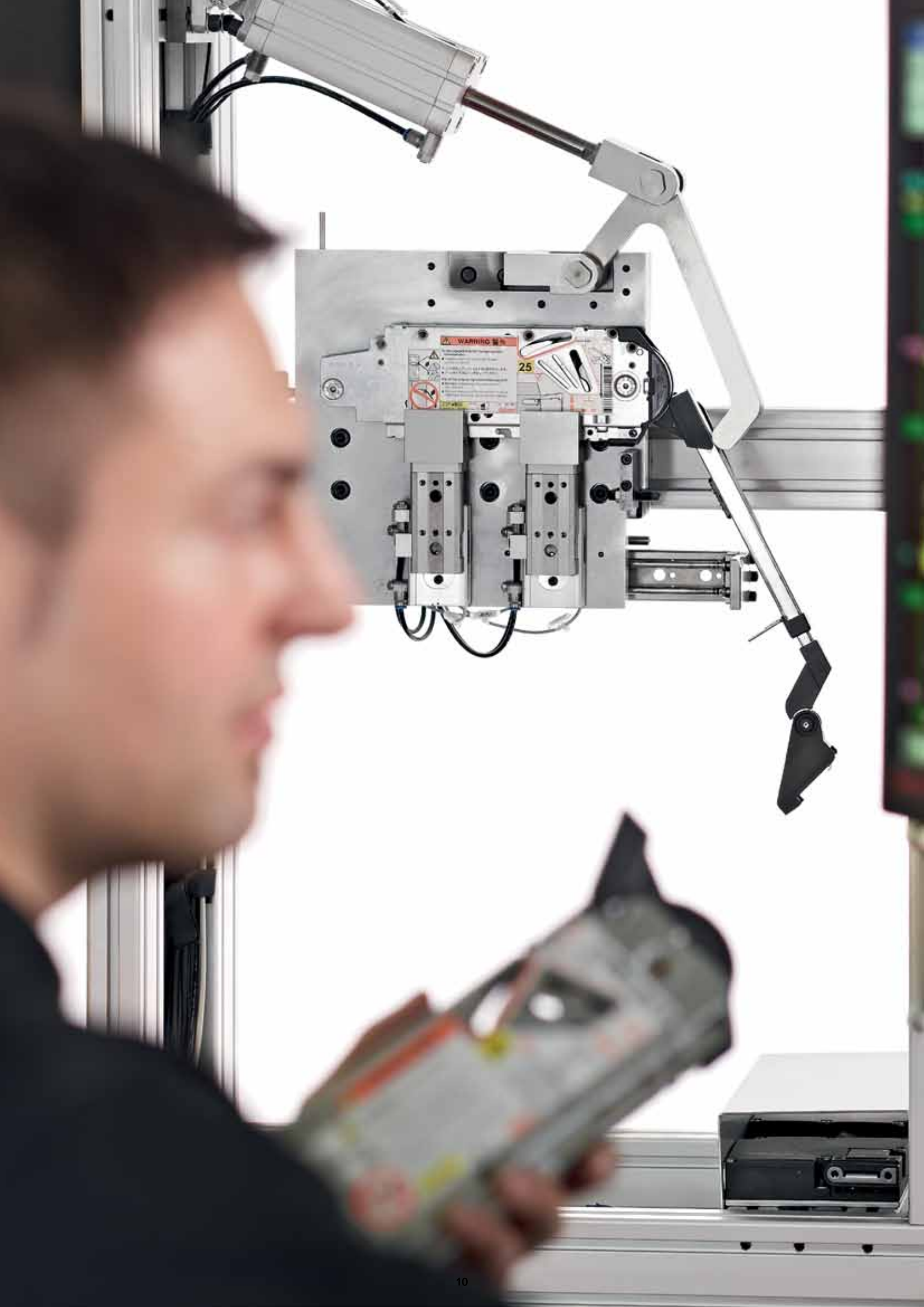

# Reliability – a furniture lifetime



We want our fitting solutions to provide your customers with many years of enjoyment and satisfaction.

That is why we focus on ensuring the highest quality:

#### Precision testing

Each fitting is tested extensively according to strict criteria. Testing is carried out at our own test labs as well as in conjunction with international testing organisations. An AVENTOS lift system goes through the opening and closing process up to 80,000 times which is double the industry requirement – only then are we satisfied in terms of our quality.

#### Long warranty

Our promise to provide “quality a furniture lifetime” naturally applies to AVENTOS as well. We are so confident of this that we also offer you a full 5-year warranty in respect of all the electrical components e.g. SERVO-DRIVE when used in combination with Blum products.

#### Meticulous selection and processes

High-quality robust materials. Exact assembly. Fast and simple assembly. From the choice of material right through to construction and start-up, we insist on consistently high levels of quality.



Easy insertion: Assembly of the cross stabiliser for AVENTOS HS and AVENTOS HL is now completely tool-free.



Just a few simple steps are required



#### Almost entirely tool-free

AVENTOS can be assembled with ease and the proven CLIP technology makes the process almost entirely tool-free. The only tool required is a power screwdriver for adjusting the lift mechanism in precise accordance with the front weight. The fact that the cross stabiliser for AVENTOS HS is attached without tools significantly reduces the amount of effort required for assembly. Fronts can be conveniently adjusted in 3 dimensions to ensure perfect gap alignment.

#### SERVO-DRIVE: Start-up made easy

SERVO-DRIVE for AVENTOS only has a few components. These are easy to attach and can be precisely adjusted. In just a few simple steps, SERVO-DRIVE can be assembled, cable added, switch installed and the system can be put into operation.



Find out more about  
SERVO-DRIVE

# FAQs



## AVENTOS

### Why is it that the lift system rises or falls when you let go?

This occurs when the lift mechanism has not been set correctly. The fine adjustment process involves using a power screwdriver and the integral calibration to adjust the lift mechanism in precise accordance with the front weight. The result: The front stays in the position required.

### Is it also possible to use opening angle stops?

Yes, it is possible for AVENTOS HF, HK and HK-S. In the case of SERVO-DRIVE for AVENTOS, the drive unit must be mounted first and once the opening angle stop has been subsequently mounted, a reference run must be performed.

### Can the AVENTOS concept be implemented without using handles?

Yes, you can equip the lift system with SERVO-DRIVE (an electrical motion support system) or TIP-ON (a mechanical opening support system). A single touch suffices and the lift systems appear to open by themselves.

## SERVO-DRIVE for AVENTOS

### Is it possible to synchronise multiple lift systems?

Yes. Up to three drive units can be set so that they move simultaneously. This is especially practical in cases where there is a shared front covering several cabinets. In addition, the "collision avoidance" function for corner solutions allows you to adjust the drive units so that only one front ever opens at a time.

### What does my customer see when the wireless switch battery has to be replaced?

The SERVO-DRIVE switch contains a battery display. It flashes red when the battery power begins to weaken. Battery replacement is very simple. All you need is a conventional button cell battery (type CR 2032).

### What happens when the power goes out?

When there is a power cut SERVO-DRIVE for AVENTOS is not activated. However, you can continue to open and close manually without restrictions.

Once the power has been restored, you can carry on using everything as normal without having to reset the SERVO-DRIVE unit.

### Can SERVO-DRIVE for AVENTOS be deactivated?

Your customers can deactivate SERVO-DRIVE for AVENTOS very easily. This is especially practical when cleaning the fronts, for example. We recommend a switched outlet for this. While deactivated, the lift systems can continue to be opened and closed manually.





# Award-winning design

## Enchanting Elegance

Along with high functionality, the AVENTOS range is sure to inspire through its simple yet elegant design. The fact that it is has received a number of international awards is testament to this.





## A vast array of options for wall cabinets

**BLUMOTION**  
inside

Compatible with.

**SERVO-DRIVE**  
by Blum

The AVENTOS HF bi-fold lift system is the ideal solution for high and mid wall units. Thanks to the two-part front, even high cabinets can be accommodated. With AVENTOS HF, there is no limit to the variety of planning and design options available. Whether your customers want wooden fronts, narrow or wide aluminium frames, combinations of different materials or even fronts of different heights, you will always be able to meet their individual requirements. Handle-less fronts can be opened using SERVO-DRIVE technology.



Watch video of the assembly and adjustment processes



Greater freedom of design: AVENTOS HF allows you to combine different materials for the lift system front.



Innovative technology that offers protection: The CLIP top centre hinge prevents fingers getting caught.



At the heart of this fitting solution is the lift mechanism with BLUMOTION and a robust spring package.





- 1** Lift mechanism
- 2** Telescopic arm
- 3a** Cover cap, left  
The left SERVO-DRIVE cover cap is used to cover the lift mechanism, drive unit and distribution cable. To cover the cabling, the cover cap can be expanded up to an internal depth of 350 mm.
- 3b** Cover cap right
- 3c** Cover cap round
- 3d** SERVO-DRIVE switch  
The SERVO-DRIVE switch is attached to the cabinet side at the bottom. The switch signals the drive unit via a wireless connection. The 2.4 GHz frequency is certified for international use.
- 3e** Blum distance bumper  
The Blum distance bumper creates and maintains the required trigger path of 2 mm.
- 4** Mounting plate for telescopic arm
- 5** Mounting plate for  
**12** CLIP top 120° hinge  
CLIP top centre hinge
- 6a** Drive unit  
The drive unit is attached without tools to the left lift mechanism. The same drive unit can be used for all lift mechanisms.
- 6b** Distribution cable  
This cable is used to supply power to the drive unit. The maximum permitted operating power is 24 V.
- 6c** Connecting node +  
**6d** cable end protector  
This node establishes the electrical connection between the distribution cable and the transformer. The cable end protector is inserted into the “open” end of the cable.
- 7** Blum transformer + flex  
**9** The Blum transformer can be used worldwide. It converts the country-specific mains voltage to 24 V direct current. You must use a flex with a regular plug for the respective country depending on the installation location.
- 8** Transformer unit housing  
The transformer is easily and securely stored in the transformer unit housing.
- 10** CLIP top 120° hinge  
(unsprung)
- 11** CLIP top centre hinge

# Order information

## Standard and SERVO-DRIVE for AVENTOS HF

Wooden fronts and wide aluminium frames symmetrical/asymmetrical

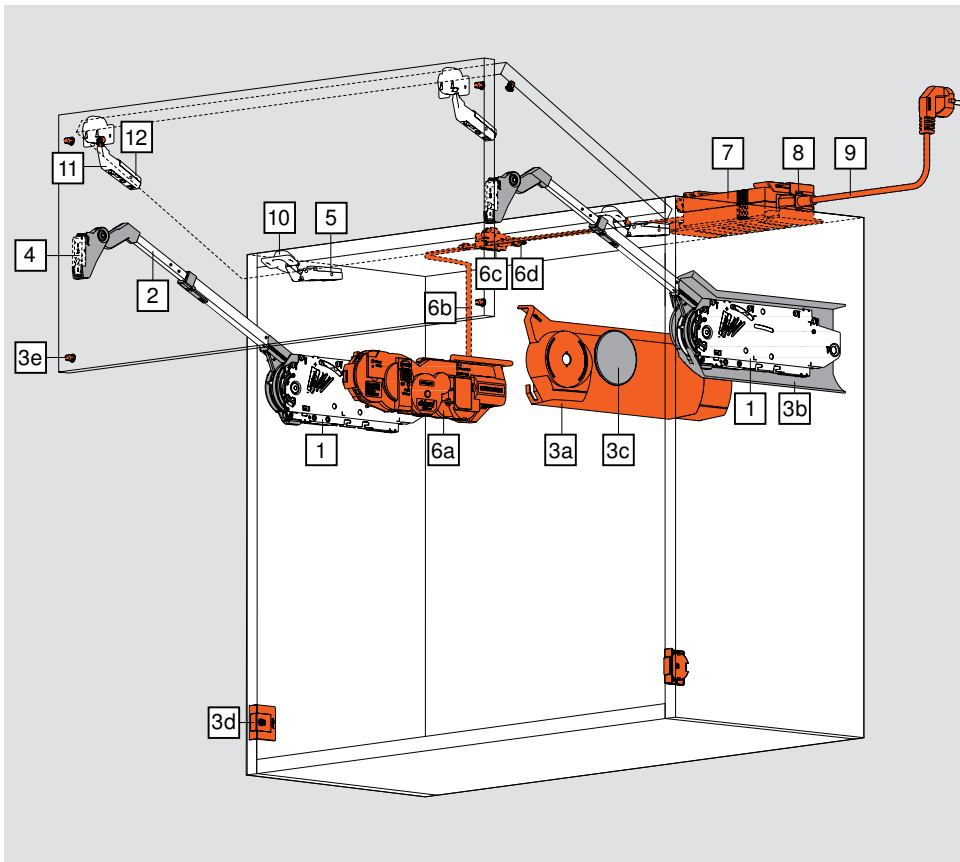

3 types of lift mechanisms are enough to cover a wide range of applications.

Using the power factor, you can calculate the number of required lift mechanisms. The power factor required depends on the weight of the lower and upper front and the cabinet height. The power factor and the door weight can be increased by 50% when a third lift mechanism is used.

The larger front must be at the top for asymmetrical fronts.

□ Standard  
 ■ SERVO-DRIVE



Power factor LF = cabinet height KH (mm) x front weight bottom and top incl. handle (kg)



■ Lift mechanism one-sided    ■ Lift mechanism two-sided    ■ Additional 3rd lift mechanism lift mechanism    LF Power factor

A trial application is recommended when you are in a borderline area of the individual lift mechanism.

<sup>1)</sup> We recommend two synchronised drive units for a power factor > 17250.

1	Lift mechanism set	2	Telescopic arm set
	Power factor LF		Nickel plated steel
	2600–5500 (1 piece LF 960–2650)		Cabinet height <sup>2)</sup> 480–570 mm
	5350–10150		Cabinet height <sup>2)</sup> 560–710 mm
	9000–17250 (3 pieces LF 13500–25900)		Cabinet height <sup>2)</sup> 700–900 mm
	Composed of:		Cabinet height <sup>2)</sup> 760–1040 mm
	2 x symmetrical lift mechanisms		Composed of:
	10 x chipboard screws Ø 4 x 35 mm		2 x symmetrical telescopic arms
			<sup>2)</sup> "Theoretical cabinet height" for asymmetrical fronts = front height top (FHO) x 2 (incl. gaps)



	3	Cover cap set		
		Nylon		
		light grey, silk white,		20F8000
		Composed of:		
3a		1 x cover cap large left		
3b		1 x cover cap large right		
3c		2 x round cover caps		

	3	Cover cap set for SERVO-DRIVE		
		Nylon		
		light grey, silk white,		21F8000
		Composed of:		
3a		1 x SERVO-DRIVE cover cap large left		
3b		1 x cover cap large right		
3c		2 x round cover caps		
3d		2 x SERVO-DRIVE switches		
3e		6 x Blum distance bumpers, Ø 5 mm		

	6	SERVO-DRIVE set		
		Nylon		
		RAL 7037 dust grey		21FA000
		Composed of:		
6a		1 x drive unit		
6b		1 x distribution cable, 1500 mm		
6c		1 x connecting node		
6d		2 x cable end protectors		

		Opening angle stop		
		Nylon		
		104° Dark grey	2 x	20F7051
		83° Dust grey	2 x	20F7011

		Hinge set		
		for wooden fronts		
		Fixing method:		
		INSERTA/EXPANDO/knock in		78Z5530T10
		Comprising of:		
10		2 x CLIP top 120° hinge o. F. <sup>3)</sup> (70T5590BTL)		
11		2 x CLIP top centre hinge (78Z5530T)		
4, 5, 12		6 x Horizontal cam mounting plate (177H5100)		
12		2 x Cruciform mounting plate (174E6100.01)		
		<sup>3)</sup> o. F. = unsprung		

		Hinge set		
		for wooden fronts and wide alu frames		
		Fixing method: Screw-on <sup>4)</sup>		78Z5500T11
		Comprising of:		
10		2 x CLIP top 120° hinge o. F. <sup>3)</sup> (70T5550.TL)		
11		2 x CLIP top centre hinge (78Z5500T)		
4, 5, 12		6 x Horizontal cam mounting plate (175H5400)		
12		2 x Cruciform cam mounting plate (173H7100)		
		<sup>3)</sup> o. F. = unsprung		
		<sup>4)</sup> Use chipboard screws (609.1x00) for wooden fronts. Use self tapping screw, countersunk head (660.0950) for wide alu frames.		

		Bit PZ cross slot		
		Size 2, length 39 mm		
				BIT-PZ KS2

	7, 8, 9	Blum transformer, flex and transformer unit housing		
			Page	74

# Planning information

## Standard and SERVO-DRIVE for AVENTOS HF

Wooden fronts and wide aluminium frames symmetrical

**Drilling position**

4 x  $\varnothing 4 \times 35$  mm  
 Drilled hole for SERVO-DRIVE distribution cable, left only

\* Drilling depth 5 mm  
 \*\* Alternative drilling

Cabinet height	H
480–549 mm	KH x 0.3 -28 mm
550–1040 mm	KH x 0.3 -57 mm

**Space requirement**

KH Cabinet height

**SERVO-DRIVE**

**Front assembly**

KH Cabinet height  
 SFA Side front overlay

**Number of hinges**  
 3 hinges starting at cabinet width 1200 mm and/or 12 kg door weight  
 4 hinges starting at cabinet width 1800 mm and/or 20 kg door weight

Cabinet height (KH)	X	X
	177H5100	177H5400E
480–549 mm	70 mm	68 mm
550–1040 mm	47 mm	45 mm

**CLIP top 120° hinge unsprung**

F Gap  
 ( ) CLIP top 120° special hinge  
 Drilling distance TB for standard hinge

	Front overlay FA																
	5	6	7	8	9	10	11	12	13	14	15	16	17				
0										3	4	5	6				
3							3	4	5	6							
6				3	4	5	6										
9	3	4	5	6													

▲ Mounting plate

**CLIP top centre hinge**

Min. gap F = 1.5 mm  
 \* 37 mm for cruciform mounting plates (37/32)  
 Drilling distance TB

	Centre gap F									
0							3	4	5	6
3							6	5	4	3
6										
9										

▲ Mounting plate





Space requirement

FH Front height

Opening angle stop

Without	$Y = FH \times 0.44 + 38 \text{ mm}$
104°	$Y = FH \times 0.24 + 34 \text{ mm}$
83°	$Y = 0 \text{ mm}$

Screw-on assembly

INSERTA/EXPANDO assembly

SERVO-DRIVE switch

Blum distance bumper

Blum distance bumper drilling position

\* From cabinet bottom edge for fronts that protrude below the cabinet

Recommendation for aluminium frames: Consider drilling Blum distance bumper holes in the cabinet side. A trial application must be carried out when fixing the Blum distance bumper to the front.

**i** Do not glue Blum distance bumper.

- Standard
- SERVO-DRIVE

# Planning information

## Standard and SERVO-DRIVE for AVENTOS HF

Wooden fronts and wide aluminium frames asymmetrical

**Drilling position**

4 x  $\text{Ø} 4 \times 35 \text{ mm}$

Drilled hole for SERVO-DRIVE distribution cable, left only

\* Drilling depth 5 mm

\*\* Alternative drilling

Cabinet height	H
480–549 mm	TKH x 0.3 - 28 mm
550–1040 mm	TKH x 0.3 - 57 mm

**Space requirement**

TKH Theoretical cabinet height

KH Cabinet height

FHo Front height top

FHu Front height bottom

Theoretical cabinet height (TKH) = front height top (FHo) x 2 (including gaps)

**Front assembly**

Min. lower front height  
 $X + 19 + \text{FAu}$

FHo Front height top

TKH Theoretical cabinet height

SFA Side front overlay

FAu Lower front overlay

**Number of hinges**  
3 hinges starting at cabinet width 1200 mm and/or 12 kg door weight  
4 hinges starting at cabinet width 1800 mm and/or 20 kg door weight

Theoretical cabinet height (TKH)	X	X
	177H5100	177H5400E
480–549 mm	$\text{FHo}/2 + 70 \text{ mm}$	$\text{FHo}/2 + 68 \text{ mm}$
550–1040 mm	$\text{FHo}/2 + 47 \text{ mm}$	$\text{FHo}/2 + 45 \text{ mm}$

**CLIP top 120° hinge unsprung**

F Gap

( ) CLIP top 120° special hinge

Drilling distance TB for standard hinge

	Front overlay FA												
	5	6	7	8	9	10	11	12	13	14	15	16	17
0										3	4	5	6
3							3	4	5	6			
6				3	4	5	6						
9	3	4	5	6									

▲ Mounting plate

**CLIP top centre hinge**

Min. gap  $F = 1.5 \text{ mm}$

\* 37 mm for cruciform mounting plates (37/32)

Drilling distance TB

	Centre gap F					
			3	4	5	6
0			6	5	4	3
3						
6						
9						

▲ Mounting plate



Space requirement

FH Front height

Opening angle stop

Without	$Y = FH \times 0.44 + 38 \text{ mm}$
104°	$Y = FH \times 0.24 + 34 \text{ mm}$
83°	$Y = 0 \text{ mm}$

Screw-on assembly

INSERTA/EXPANDO assembly

SERVO-DRIVE switch

Blum distance bumper

Blum distance bumper drilling position

\* From cabinet bottom edge for fronts that protrude below the cabinet

Recommendation for aluminium frames: Consider drilling Blum distance bumper holes in the cabinet side. A trial application must be carried out when fixing the Blum distance bumper to the front.

**i** Do not glue Blum distance bumper.

- Standard
- SERVO-DRIVE

# Order information

## Standard and SERVO-DRIVE for AVENTOS HF

### Narrow aluminium frames symmetrical/asymmetrical

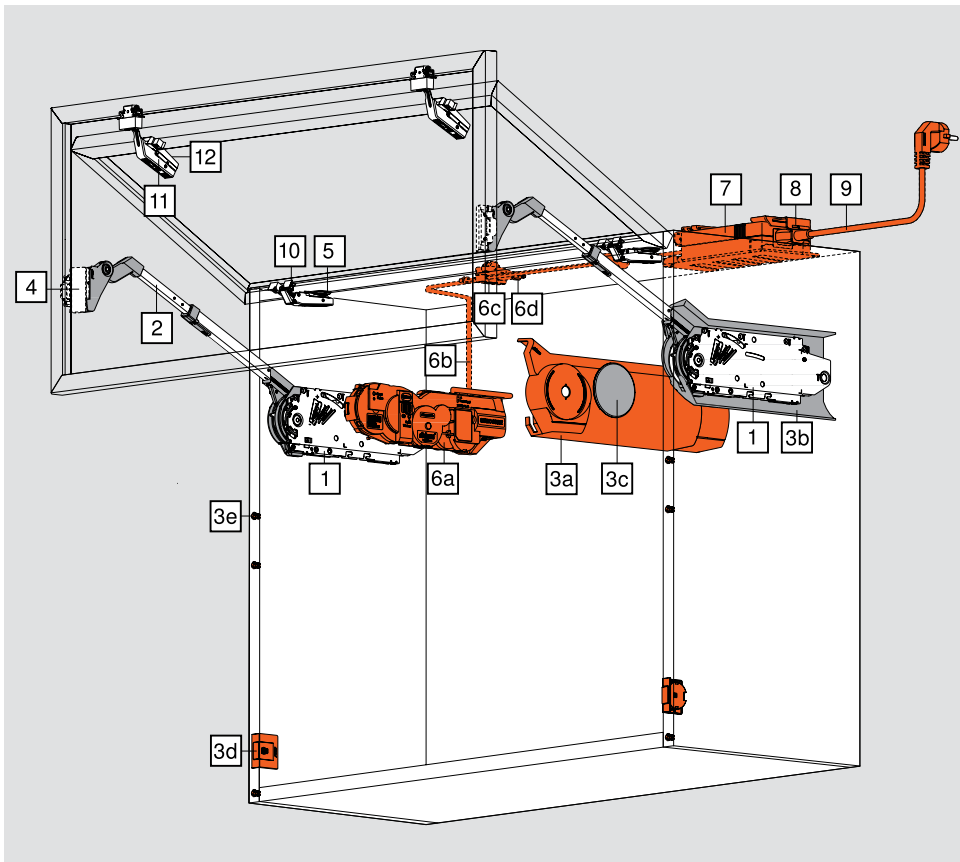

3 types of lift mechanisms are enough to cover a wide range of applications.

Using the power factor, you can calculate the number of required lift mechanisms. The power factor required depends on the weight of the lower and upper front and the cabinet height.

The larger front must be at the top for asymmetrical fronts.

□ Standard  
 ■ SERVO-DRIVE



Power factor LF = cabinet height KH (mm) x front weight bottom and top incl. handle (kg)

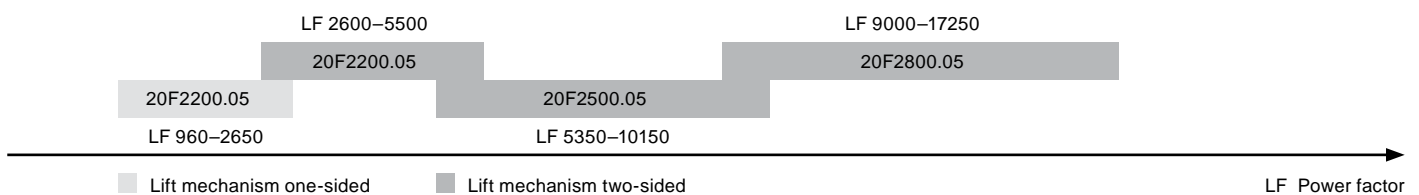

A trial application is recommended when you are in a borderline area of the individual lift mechanism.

1	Lift mechanism set	
	Power factor LF	
	2600-5500 (1 piece LF 960-2650)	20F2200.05
	5350-10150	20F2500.05
	9000-17250 (3 pieces LF 13500-25900)	20F2800.05
Composed of:		
2 x symmetrical lift mechanisms		
10 x chipboard screws Ø 4 x 35 mm		

2	Telescopic arm set	
	Nickel plated steel	
	Cabinet height <sup>2)</sup> 480-570 mm	20F3200.01
	Cabinet height <sup>2)</sup> 560-710 mm	20F3500.01
	Cabinet height <sup>2)</sup> 700-900 mm	20F3800.01
	Cabinet height <sup>2)</sup> 760-1040 mm	20F3900.01
Composed of:		
2 x symmetrical telescopic arms		
<sup>2)</sup> "Theoretical cabinet height" for asymmetrical fronts = front height top (FHO) x 2 (incl. gaps)		



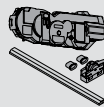

	<b>3</b>	<b>Cover cap set</b>	
		Nylon	
		light grey, silk white,	<b>20F8000</b>
		Composed of:	
<b>3a</b>		1 x cover cap large left	
<b>3b</b>		1 x cover cap large right	
<b>3c</b>		2 x round cover caps	

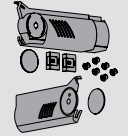
	<b>6</b>	<b>SERVO-DRIVE set</b>	
		Nylon	
		RAL 7037 dust grey	<b>21FA000</b>
		Composed of:	
<b>6a</b>		1 x drive unit	
<b>6b</b>		1 x distribution cable, 1500 mm	
<b>6c</b>		1 x connecting node	
<b>6d</b>		2 x cable end protectors	

	<b>3</b>	<b>Cover cap set for SERVO-DRIVE</b>	
		Nylon	
		light grey, silk white,	<b>21F8000</b>
		Composed of:	
<b>3a</b>		1 x SERVO-DRIVE cover cap large left	
<b>3b</b>		1 x cover cap large right	
<b>3c</b>		2 x round cover caps	
<b>3d</b>		2 x SERVO-DRIVE switches	
<b>3e</b>		6 x Blum distance bumpers, Ø 5 mm	

		<b>Hinge set</b>	
		for narrow alu frames	
		Fixing method: screw-on	<b>78Z5500T11</b>
		Comprising of:	
<b>10</b>		2 x CLIP top 120° alu frame hinge o. F. <sup>2)</sup> (72T550A.TL)	
<b>11</b>		2 x CLIP top alu frame centre hinge (78Z550AT)	
<b>12</b>		2 x CLIP adapter plate symmetrical (175H5A00)	
<b>4</b>		2 x CLIP adapter plate left/right (175H5B00)	
<b>5</b>		2 x Horizontal cam mounting plate (175H5400)	
		<sup>2)</sup> o. F. = unsprung	

		<b>Bit PZ cross slot</b>	
		Size 2, length 39 mm	<b>BIT-PZ KS2</b>

	<b>7, 8, 9</b>	<b>Blum transformer, flex and transformer unit housing</b>	
			<b>Side 74</b>

# Planning information

## Standard and SERVO-DRIVE for AVENTOS HF

### Narrow aluminium frames symmetrical

Drilling position

4 x Ø 4 x 35 mm

Drilled hole for SERVO-DRIVE distribution cable, left only

\* Drilling depth 5 mm

\*\* Alternative drilling

Cabinet height	H
480–549 mm	KH x 0.3 - 28 mm
550–1040 mm	KH x 0.3 - 57 mm

Space requirement

min 278

min 72.5

min 22

KH Cabinet height

**SERVO-DRIVE**

29

68

29

Front assembly

KH Cabinet height

**Number of hinges**

3 hinges starting at cabinet width 1200 mm and/or 12 kg door weight

4 hinges starting at cabinet width 1800 mm and/or 20 kg door weight

Cabinet height	X
480–549 mm	54 mm
550–1040 mm	31 mm

CLIP top 120° alu frame hinge unsprung

19.5

66.5

1.7

15

19

CLIP top alu frame centre hinge

21

66

19.5

19.5

3

Min. gap F = 1.5 mm

An adjustment has to be made for frame thicknesses over 20.5 mm

- Standard
- SERVO-DRIVE



**Space requirement**

FH Front height

Opening angle stop

Without	$Y = FH \times 0.44 + 38 \text{ mm}$
104°	$Y = FH \times 0.24 + 34 \text{ mm}$
83°	$Y = 0 \text{ mm}$

**Front assembly**

\* When changing material thickness, adjust the assembly dimensions accordingly

**SERVO-DRIVE switch**

**Blum distance bumper drilling position**

**Blum distance bumper**

\* From cabinet bottom edge for fronts that protrude below the cabinet

Recommendation for aluminium frames: Consider drilling Blum distance bumper holes in the cabinet side. A trial application must be carried out when fixing the Blum distance bumper to the front.

**i** Do not glue Blum distance bumper.

# Planning information

## Standard and SERVO-DRIVE for AVENTOS HF

### Narrow aluminium frames asymmetrical

Drilling position

**SERVO-DRIVE**

4 x  $\text{Ø} 4 \times 35 \text{ mm}$

Drilled hole for SERVO-DRIVE distribution cable, left only

\* Drilling depth 5 mm

\*\* Alternative drilling

TKH	H
480–549 mm	TKH x 0.3 - 28 mm
550–1040 mm	TKH x 0.3 - 57 mm

Space requirement

**SERVO-DRIVE**

TKH Theoretical cabinet height

KH Cabinet height

FHo Front height top

FHu Front height bottom

Theoretical cabinet height (TKH) = upper front height (FHO) x 2 (including gaps)

Front assembly

Min. measurement for front height bottom  
 $X + 33 + \text{FAu}$

FHo Front height top

TKH Theoretical cabinet height

FHu Front height bottom

FAu Lower front overlay

**Number of hinges**

3 hinges starting at cabinet width 1200 mm and/or 12 kg door weight

4 hinges starting at cabinet width 1800 mm and/or 20 kg door weight

TKH	X
480–549 mm	$\text{FHo}/2 + 54 \text{ mm}$
550–1040 mm	$\text{FHo}/2 + 31 \text{ mm}$

CLIP top 120° alu frame hinge unsprung

CLIP top alu frame centre hinge

Min. gap F = 1.5 mm

An adjustment has to be made for frame thicknesses over 20.5 mm





Space requirement

FH Front height

Opening angle stop

Without	$Y = FH \times 0.44 + 38 \text{ mm}$
104°	$Y = FH \times 0.24 + 34 \text{ mm}$
83°	$Y = 0 \text{ mm}$

Front assembly

\* When changing material thickness, adjust the assembly dimensions accordingly

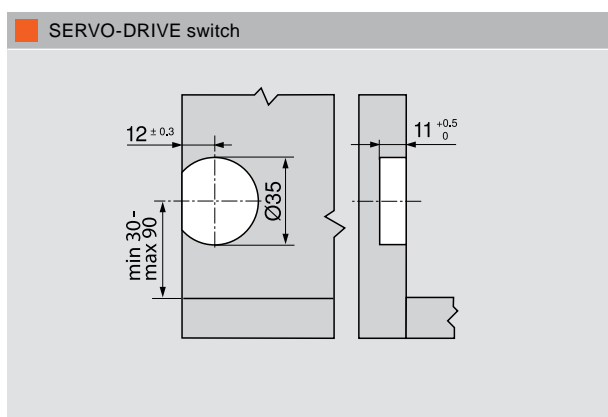

Blum distance bumper drilling position

\* From cabinet bottom edge for fronts that protrude below the cabinet

Recommendation for aluminium frames: Consider drilling Blum distance bumper holes in the cabinet side. A trial application must be carried out when fixing the Blum distance bumper to the front.

**i** Do not glue Blum distance bumper.

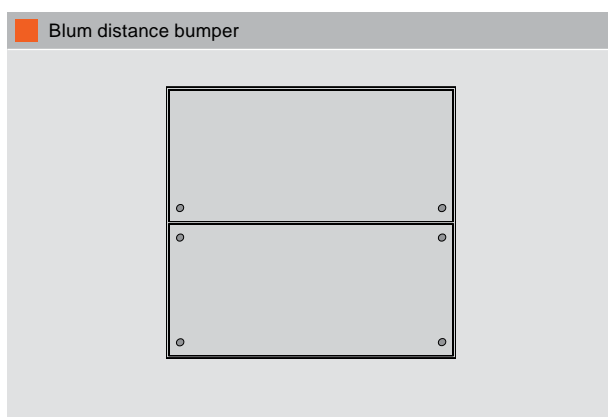

- Standard
- SERVO-DRIVE



## Room for beautiful details

**BLUMOTION**  
inside

Compatible with.

**SERVO-DRIVE**  
by Blum

With the lift system fitting for AVENTOS HS, even large, one-part fronts appear to defy gravity by swinging up effortlessly. There is still enough space over the cabinet for a host of design options, such as beautiful details in the form of cornice or crown mouldings. As you would expect, this product is just as easy to assemble as the others and the process is almost entirely tool-free. Handle-less fronts can be opened using SERVO-DRIVE technology and without any need for hinges.



Watch video of the assembly and adjustment processes



Tailored to your tastes: AVENTOS HS also allows wall cabinets to be decorated with cornice or crown mouldings.

At the heart of this fitting solution is the lift mechanism with BLUMOTION and a robust spring package.

# AVENTOS HS

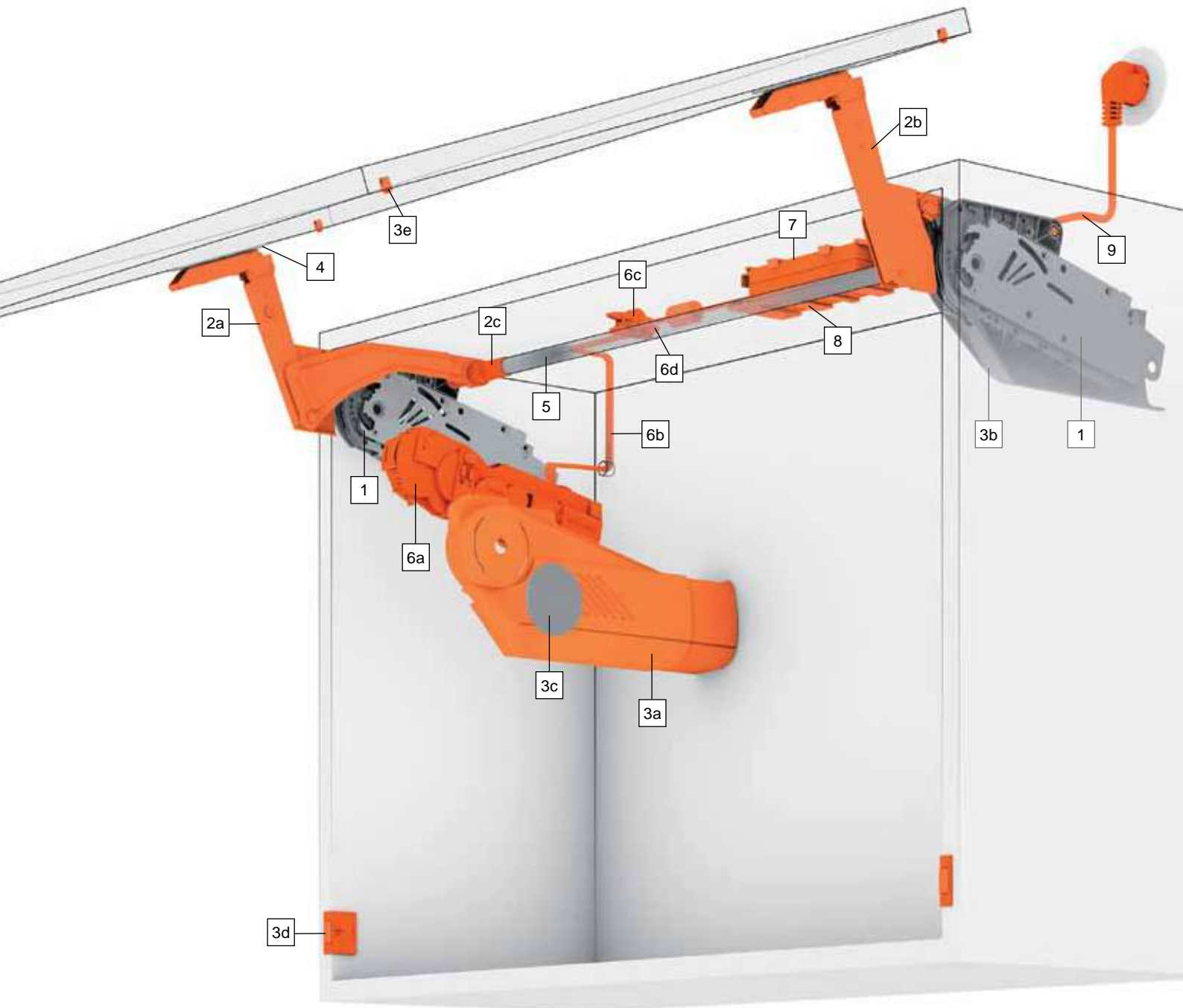

- Standard
- SERVO-DRIVE



- 1** Lift mechanism
- 2a** Lever arm
- 2b**
- 2c** Cross stabiliser cover cap
- 3a** Cover cap, left  
The left SERVO-DRIVE cover cap is used to cover the lift mechanism, drive unit and distribution cable. To cover the cabling, the cover cap can be expanded up to an internal depth of 350 mm.
- 3b** Cover cap right
- 3c** Cover cap round
- 3d** SERVO-DRIVE switch  
The SERVO-DRIVE switch is attached to the cabinet side at the bottom. The switch signals the drive unit via a wireless connection. The 2.4 GHz frequency is certified for international use.
- 3e** Blum distance bumper  
The Blum distance bumper creates and maintains the required trigger path of 2 mm.
- 4** Front fixing bracket
- 5** Cross stabiliser rod round
- 6a** Drive unit  
The drive unit is attached without tools to the left lift mechanism. The same drive unit can be used for all lift mechanisms.
- 6b** Distribution cable  
This cable is used to supply power to the drive unit. The maximum permitted operating power is 24 V.
- 6c** Connecting node +  
**6d** cable end protector  
This node establishes the electrical connection between the distribution cable and the transformer. The cable end protector is inserted into the "open" end of the cable.
- 7** Blum transformer + flex  
**9** The Blum transformer can be used worldwide. It converts the country-specific mains voltage to 24 V direct current. You must use a flex with a regular plug for the respective country depending on the installation location.
- 8** Transformer unit housing  
The transformer is easily and securely stored in the transformer unit housing.

# Order information

## Standard and SERVO-DRIVE for AVENTOS HS

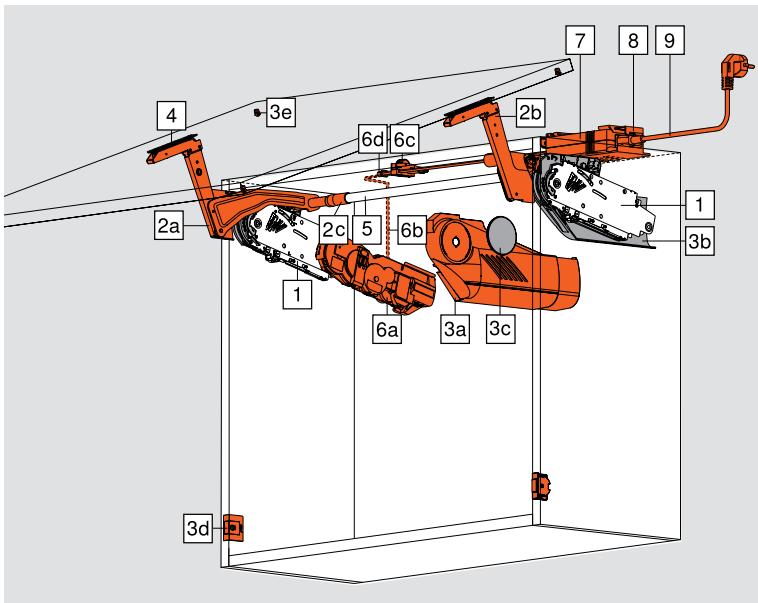

	<b>1</b>	<b>Lift mechanism set</b>			
		KH 350–525 mm	20S2A00.05	20S2B00.05	20S2C00.05
		KH 526–675 mm	20S2D00.05	20S2E00.05	20S2F00.05
		KH 676–800 mm	20S2G00.05	20S2H00.05	20S2I00.05
		Composed of:			
		2 x symmetrical lift mechanisms			
		10 x chipboard screws Ø 4 x 35 mm			

	<b>2</b>	<b>Lever arm set</b>			
		Steel, nickel plated			20S3500.06
		Composed of:			
	2a	1 x lever arm left			
	2b	1 x lever arm right			
	2c	2 x cross stabiliser cover caps			

	<b>2</b>	<b>Lever arm set for SERVO-DRIVE</b>			
		Steel, nickel plated			21S3500.01
		Includes:			
	2a	1 x SERVO-DRIVE lever arm left			
	2b	1 x SERVO-DRIVE lever arm right			
	2c	2 x cross stabiliser cover caps			

	<b>3</b>	<b>Cover cap set</b>			
		Nylon			20S8000
		light grey, silk white			
		Composed of:			
	2a	1 x cover cap large left			
	2b	1 x cover cap large right			
	2c	2 x round cover caps			

	<b>3</b>	<b>Cover cap set for SERVO-DRIVE</b>			
		Nylon			21S8000
		light grey, silk white			
		Composed of:			
	3a	1 x SERVO-DRIVE cover cap large left			
	3b	1 x cover cap large right			
	3c	2 x round cover caps			
	3d	2 x SERVO-DRIVE switches			
	3e	4 x Blum distance bumpers, Ø 5 mm			

	<b>4</b>	<b>Front fixing bracket set</b>			
		Nickel plated			
		Wooden fronts and wide aluminium frames <sup>1)</sup>			20S42E1
		Narrow alu frames			20S4200A

<sup>1)</sup> Use 4 chipboard screws (609.1x00) per side for wooden fronts. Use 4 countersunk self tapping screws (660.0950) per side for wide aluminium frames.

	<b>5</b>	<b>Cross stabiliser rod round</b>			
		Aluminium, Ø 16 mm			
		For cutting to size, 1061 mm			20Q1061UN
		<b>Cutting:</b> LW - 129 mm			
		SERVO-DRIVE: LW - 164 mm			

		<b>Connecting piece set for cross stabiliser</b>			
		Aluminium, Ø 16 mm			
		With LW of 1190 mm and up			20Q153ZN
		<b>Cutting for 5:</b> LW / 2 - 147 mm			
		SERVO-DRIVE: LW / 2 - 165 mm			
		Composed of:			
		1 x connecting piece			
		1 x fixing			
		2 x cross stabiliser cover caps			

	<b>6</b>	<b>SERVO-DRIVE set</b>			
		Nylon			
		RAL 7037 dust grey			21FA000
		Composed of:			
	6a	1 x drive unit			
	6b	1 x distribution cable, 1500 mm			
	6c	1 x connecting node			
	6d	2 x cable end protectors			
		We recommend one SERVO-DRIVE drive unit per set for connected fronts!			

	Standard	KH	Cabinet height
	SERVO-DRIVE	LW	Inner cabinet width



	Bit PZ cross slot
	Size 2, length 39 mm
	<b>BIT-PZ KS2</b>

	7, 8, 9	Blum transformer, flex and transformer unit housing
		Page <b>74</b>

The cabinet front and door weight is required in order to select the correct lift mechanism.

**Example:** KH = 600 mm, weight of front = 10 kg

Lift mechanism selection = **20S2E00.05**

KH = 602 mm → 600 mm, KH = 603 mm → 605 mm

KH (mm)	Door weight (kg)		
	20S2G00.05	20S2H00.05	20S2I00.05
800	4.00–7.00	6.00–12.25	10.50–20.00
795	4.00–7.00	6.00–12.25	10.50–20.00
790	4.00–7.00	6.00–12.25	10.75–20.00
785	4.00–7.00	6.25–12.50	10.75–20.00
780	4.00–7.00	6.25–12.50	10.75–20.25
775	3.75–7.00	6.25–12.50	11.00–20.25
770	3.75–7.00	6.25–12.50	11.00–20.25
765	3.75–7.25	6.50–12.50	11.00–20.25
760	3.75–7.25	6.50–12.75	11.25–20.25
755	3.75–7.25	6.50–12.75	11.25–20.50
750	3.50–7.25	6.50–12.75	11.50–20.50
745	3.50–7.25	6.50–12.75	11.50–20.50
740	3.50–7.25	6.50–12.75	11.75–20.75
735	3.50–7.50	6.50–13.00	11.75–20.75
730	3.50–7.50	6.75–13.00	11.75–21.00
725	3.50–7.50	6.75–13.00	12.00–21.00
720	3.50–7.50	6.75–13.00	12.00–21.25
715	3.50–7.50	6.75–13.00	12.00–21.25
710	3.50–7.75	6.75–13.25	12.25–21.25
705	3.50–7.75	6.75–13.25	12.25–21.50
700	3.50–7.75	6.75–13.25	12.50–21.50
695	3.50–7.75	6.75–13.25	12.50–21.50
690	3.50–7.75	6.75–13.25	12.75–21.50
685	3.50–8.00	7.00–13.25	12.75–21.50
680	3.50–8.00	7.00–13.50	13.00–21.50
676	3.50–8.00	7.00–13.50	13.00–21.50

KH (mm)	Door weight (kg)		
	20S2D00.05	20S2E00.05	20S2F00.05
675	3.00–5.25	5.00–11.00	09.75–19.00
670	3.00–5.25	5.00–11.00	09.75–19.00
665	3.00–5.25	5.00–11.00	09.75–19.00
660	3.00–5.50	5.25–11.25	10.00–19.00
655	3.00–5.50	5.25–11.25	10.00–19.00
650	3.00–5.50	5.25–11.25	10.00–19.00
645	3.00–5.50	5.25–11.25	10.00–18.75
640	3.00–5.50	5.25–11.25	10.00–18.75
635	3.00–5.50	5.25–11.50	10.25–18.75
630	3.00–5.75	5.50–11.50	10.25–18.75
625	3.00–5.75	5.50–11.50	10.25–18.75

620	3.00–5.75	5.50–11.50	10.25–18.75
615	3.00–5.75	5.50–11.50	10.25–18.75
610	3.00–6.00	5.50–11.75	10.50–18.50
605	3.00–6.00	5.50–11.75	10.50–18.50
600	3.00–6.00	5.50–11.75	10.50–18.50
595	3.00–6.00	5.50–11.75	10.50–18.50
590	3.00–6.00	5.50–12.00	10.75–18.25
585	3.00–6.25	5.75–12.00	10.75–18.25
580	3.00–6.25	5.75–12.00	11.00–18.00
575	3.00–6.25	5.75–12.00	11.00–18.00
570	3.00–6.25	5.75–12.25	11.25–17.75
565	3.00–6.25	5.75–12.25	11.25–17.75
560	3.00–6.50	6.00–12.25	11.25–17.50
555	3.00–6.50	6.00–12.50	11.50–17.50
550	3.00–6.50	6.00–12.50	11.50–17.25
545	3.00–6.50	6.00–12.50	11.50–17.25
540	3.00–6.50	6.00–12.75	11.75–17.00
535	3.00–6.75	6.25–12.75	11.75–16.75
530	3.00–6.75	6.25–12.75	11.75–16.75
526	3.00–6.75	6.25–13.00	12.00–16.50

KH (mm)	Door weight (kg)		
	20S2A00.05	20S2B00.05	20S2C00.05
525	2.50–4.00	3.25–7.50	7.25–15.00
520	2.50–4.00	3.50–7.50	7.25–15.00
515	2.50–4.00	3.50–7.50	7.25–14.75
510	2.50–4.00	3.50–7.75	7.50–14.75
505	2.50–4.00	3.50–7.75	7.50–14.75
500	2.50–4.25	3.50–7.75	7.50–14.75
495	2.50–4.25	3.75–7.75	7.50–14.50
490	2.50–4.25	3.75–8.00	7.75–14.50
485	2.50–4.25	3.75–8.00	7.75–14.25
480	2.50–4.25	3.75–8.00	7.75–14.25
475	2.50–4.25	3.75–8.00	7.75–14.00
470	2.50–4.25	4.00–8.25	8.00–14.00
465	2.25–4.25	4.00–8.25	8.00–13.75
460	2.25–4.25	4.00–8.25	8.00–13.75
455	2.25–4.25	4.00–8.50	8.25–13.50
450	2.25–4.25	4.00–8.50	8.25–13.50
445	2.25–4.50	4.25–8.50	8.25–13.25
440	2.25–4.50	4.25–8.50	8.25–13.00
435	2.25–4.50	4.25–8.75	8.50–13.00
430	2.25–4.50	4.25–8.75	8.50–12.75
425	2.25–4.50	4.25–8.75	8.50–12.75
420	2.25–4.50	4.25–8.75	8.50–12.50
415	2.25–4.50	4.25–8.75	8.50–12.50
410	2.25–4.50	4.25–9.00	8.75–12.25
405	2.25–4.50	4.25–9.00	8.75–12.00
400	2.00–4.75	4.25–9.00	8.75–12.00
395	2.00–4.75	4.50–9.00	8.75–11.75
390	2.00–4.75	4.50–9.00	8.75–11.50
385	2.00–4.75	4.50–9.25	9.00–11.50
380	2.00–4.75	4.50–9.25	9.00–11.25
375	2.00–4.75	4.50–9.25	9.00–11.25
370	2.00–4.75	4.50–9.25	9.00–11.00
365	2.00–4.75	4.50–9.25	9.00–11.00
360	2.00–4.75	4.50–9.50	9.25–10.75
355	2.00–4.75	4.50–9.50	9.25–10.50
350	2.00–5.00	4.50–9.50	9.25–10.50

# Planning information

## Standard and SERVO-DRIVE for AVENTOS HS

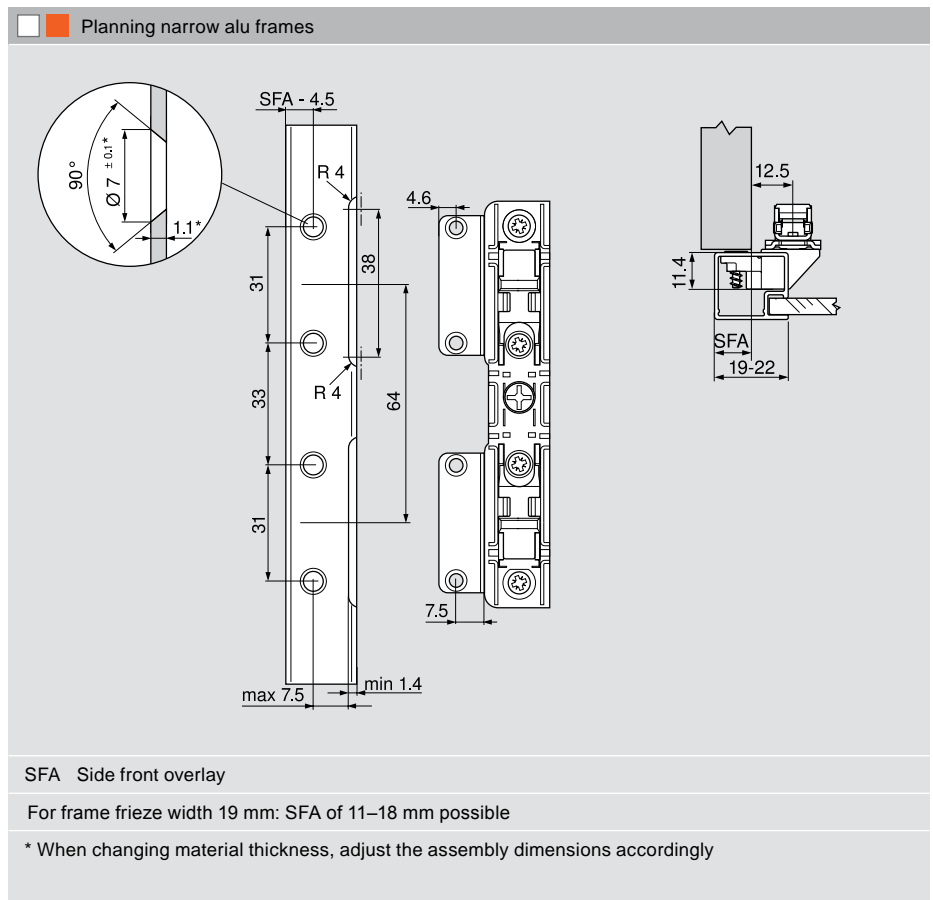
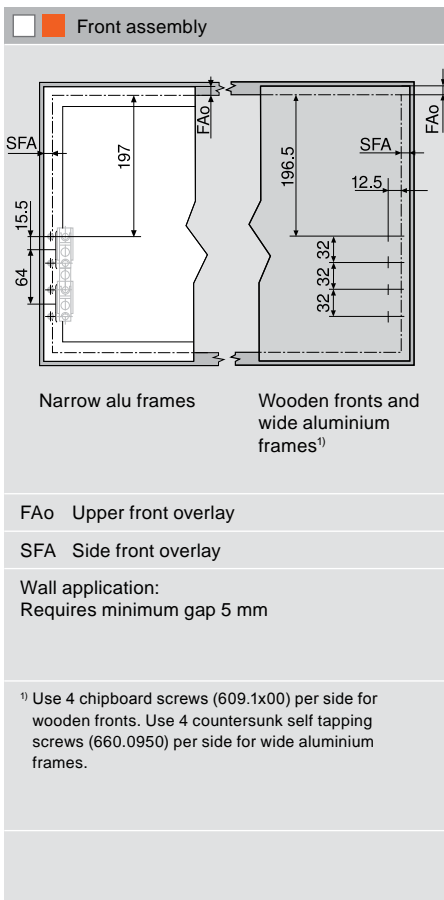
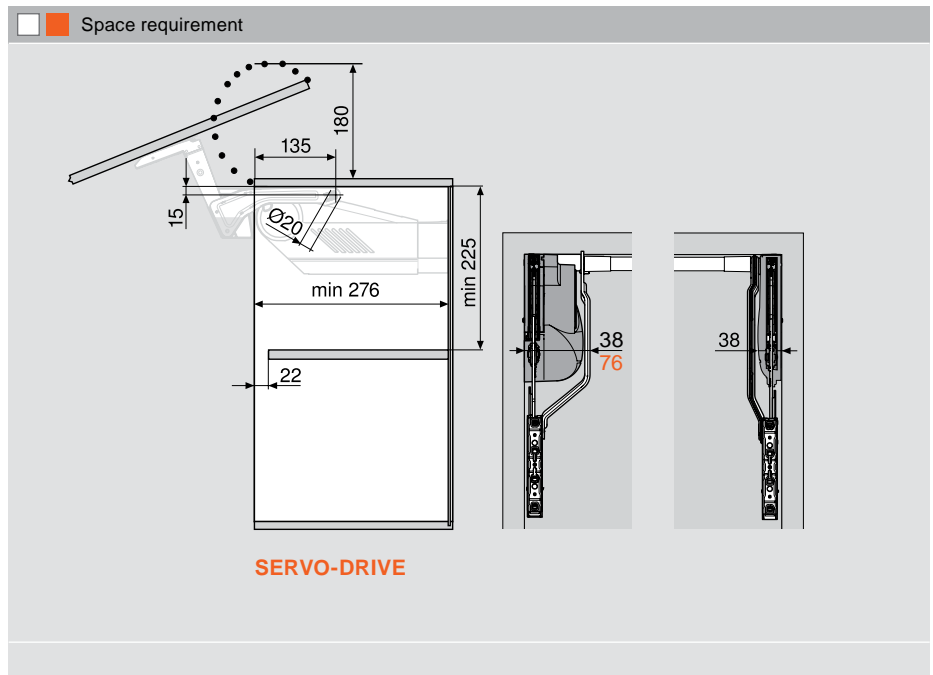
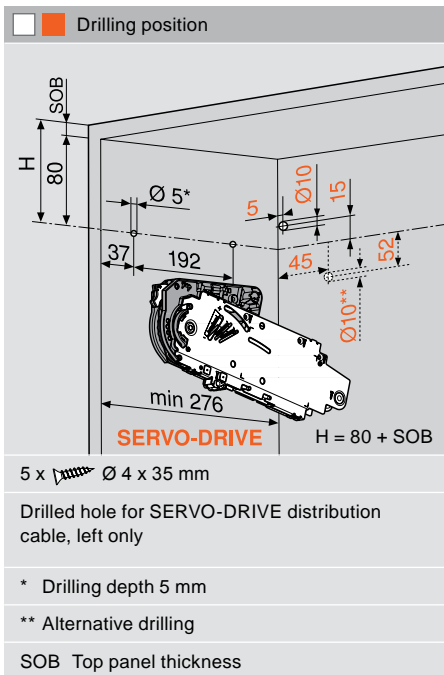

Standard

SERVO-DRIVE





**Front setting**

Dimensions depend on tilt adjustment

**Cornice and crown moulding clearance**

Gap F	X max	Y max
3 mm	35 mm	101 mm
2 mm	31 mm	101 mm
1.5 mm	28 mm	101 mm

**Cross stabiliser**

[1] LW -129 mm  
SERVO-DRIVE: LW -164 mm

Connecting piece

[2] Half LW -147 mm  
SERVO-DRIVE: Half LW -165 mm

LW Internal width

**SERVO-DRIVE switch**

**Blum distance bumper drilling position**

\* From cabinet bottom edge for fronts that protrude below the cabinet

Recommendation for aluminium frames: Consider drilling Blum distance bumper holes in the cabinet side. A trial application must be carried out when fixing the Blum distance bumper to the front.

**i** Do not glue Blum distance bumper.

**Blum distance bumper**



Easy **access**  
combined with  
visual **appeal**

**BLUMOTION**  
inside

Compatible with.

**SERVO-DRIVE**  
by Blum

This product is a brilliant combination of design and function. As its name suggests, the AVENTOS HL “lift up” lifts right up and out of the user’s way so that everything is always within easy reach. As a result, even special installations are possible. For example, you can integrate electrical appliances into tall cabinets. Handle-less fronts can be opened using SERVO-DRIVE technology and without any need for hinges.



Watch video of the assembly and adjustment processes



Sheer beauty: With AVENTOS HL, electrical appliances disappear behind a continuous cabinet front.



At the heart of this fitting solution is the lift mechanism with BLUMOTION and a robust spring package.

# AVENTOS HL

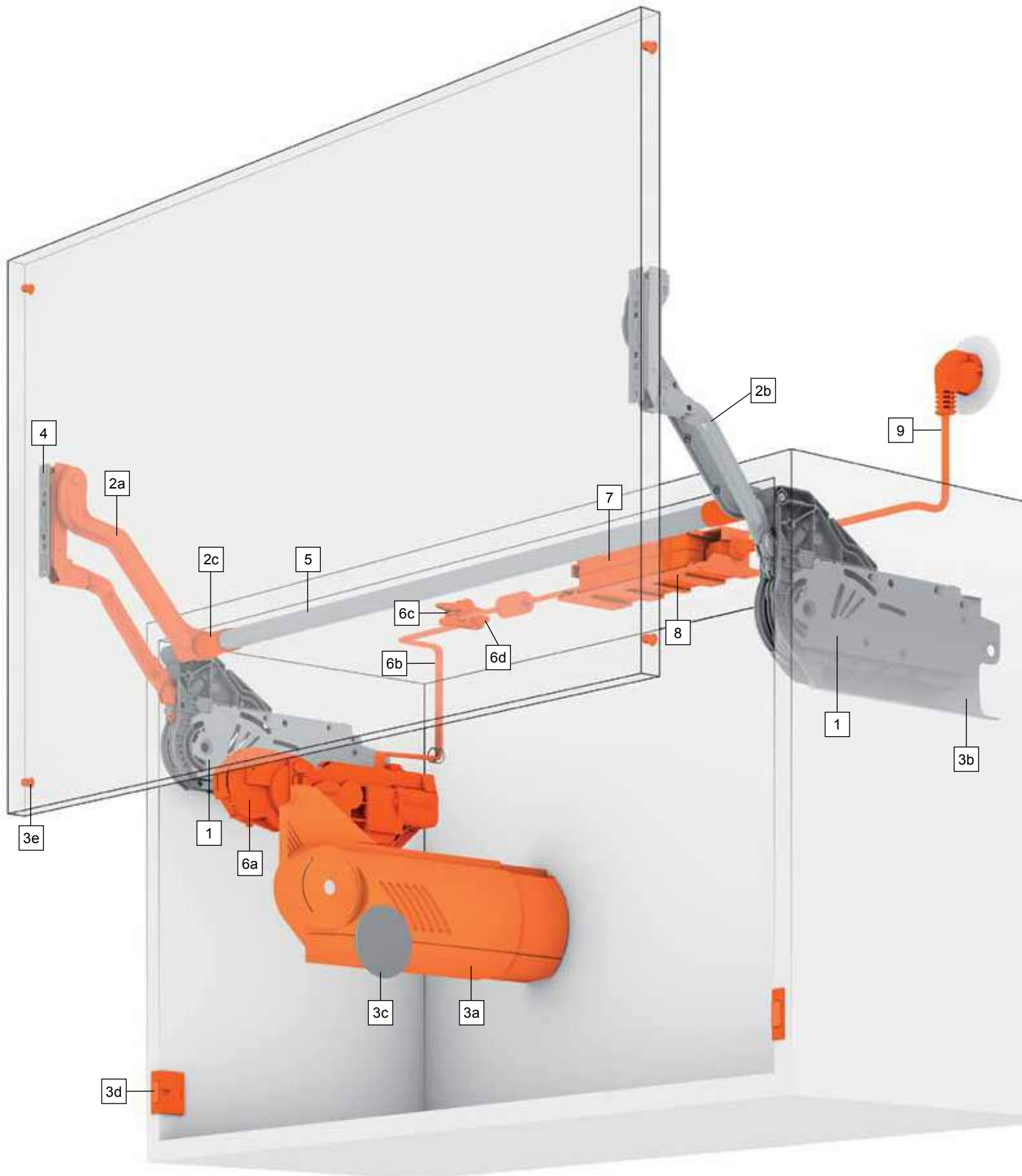

- Standard
- SERVO-DRIVE



- 1** Lift mechanism
- 2a** Lever arm left
- 2b** Lever arm right
- 2c** Cross stabiliser cover cap
- 3a** Cover cap, left  
The left SERVO-DRIVE cover cap is used to cover the lift mechanism, drive unit and distribution cable. To cover the cabling, the cover cap can be expanded up to an internal depth of 350 mm.
- 3b** Cover cap right
- 3c** Cover cap round
- 3d** SERVO-DRIVE switch  
The SERVO-DRIVE switch is attached to the cabinet side at the bottom. The switch signals the drive unit via a wireless connection. The 2.4 GHz frequency is certified for international use.
- 3e** Blum distance bumper  
The Blum distance bumper creates and maintains the required trigger path of 2 mm.
- 4** Front fixing bracket
- 5** Oval cross stabiliser
- 6a** Drive unit  
The drive unit is attached without tools to the left lift mechanism. The same drive unit can be used for all lift mechanisms.
- 6b** Distribution cable  
This cable is used to supply power to the drive unit. The maximum permitted operating power is 24 V.
- 6c** Connecting node +  
**6d** cable end protector  
This node establishes the electrical connection between the distribution cable and the transformer. The cable end protector is inserted into the “open” end of the cable.
- 7** Blum transformer + flex  
**9** The Blum transformer can be used worldwide. It converts the country-specific mains voltage to 24 V direct current. You must use a flex with a regular plug for the respective country depending on the installation location.
- 8** Transformer unit housing  
The transformer is easily and securely stored in the transformer unit housing.

# Order information

## Standard and SERVO-DRIVE for AVENTOS HL

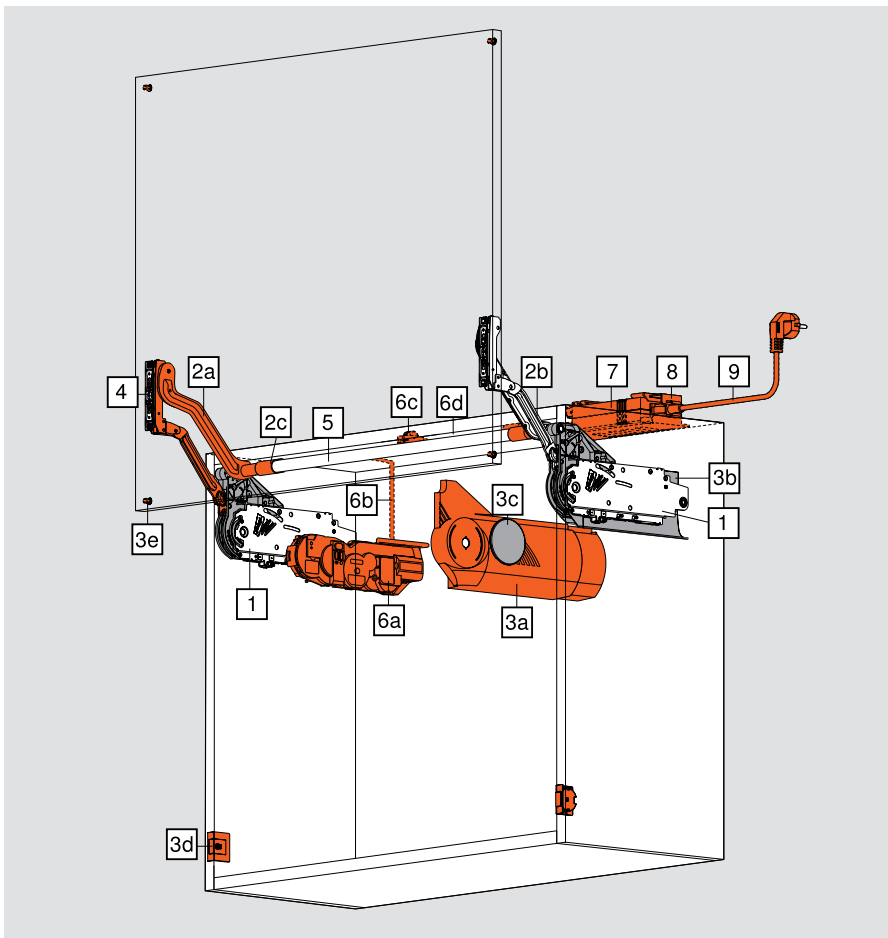

5 types of lift mechanisms are enough to cover a wide range of applications.

In order to select the correct lift mechanism, it is necessary to establish both the cabinet height and the weight of the front (including the handle).

□ Standard  
 ■ SERVO-DRIVE

	Cabinet height			
	300–349 mm	350–399 mm	400–550 mm	450–580 mm
	Lever arm set			
	□ 20L3200.06	□ 20L3500.06	□ 20L3800.06	□ 20L3900.06
Lift mechanism set	■ 21L3200.01	■ 21L3500.01	■ 21L3800.01	■ 21L3900.01
20L2100.05	1.25–4.25 kg	1.25–2.50 kg		
20L2300.05	3.50–7.25 kg	1.75–5.00 kg	1.75–3.50 kg	
20L2500.05	6.50–12.00 kg	4.25–9.00 kg	2.75–6.75 kg	2.00–5.25 kg
20L2700.05	11.00–20.00 kg	8.00–14.75 kg	5.75–11.75 kg	4.25–9.25 kg
20L2900.05		13.50–20.00 kg	10.50–20.00 kg	8.25–16.50 kg

A trial application is recommended when you are in a borderline area of the individual lift mechanism.

1	Lift mechanism set	2	Lever arm set
	20L2100.05		Cabinet height 300–349 mm
	20L2300.05		20L3200.06
	20L2500.05		20L3500.06
	20L2700.05		20L3800.06
	20L2900.05		20L3900.06
Composed of:		Composed of:	
2 x symmetrical lift mechanisms		2a	1 x lever arm left
10 x chipboard screws Ø 4 x 35 mm		2b	1 x lever arm right
		2c	2 x cross stabiliser cover caps



# Planning information

## Standard and SERVO-DRIVE for AVENTOS HL

Drilling position

**SERVO-DRIVE**

5 x  $\times$  Ø 4 x 35 mm

Drilled hole for SERVO-DRIVE distribution cable, left only

\* Drilling depth 5 mm

\*\* Alternative drilling

SOB Top panel thickness

Space requirement

**SERVO-DRIVE**

Lever arm set		min LH*	Y*	LH	Internal cabinet height
<input type="checkbox"/>	<input checked="" type="checkbox"/>	mm	mm	KH	Cabinet height
20L3200.06	21L3200.01	262	264		
20L3500.06	21L3500.01	312	352		
20L3800.06	21L3800.01	362	440		* Dimensions apply to lower gap = 0 mm
20L3900.06	21L3900.01	412	529		

Front assembly

**Narrow alu frames**

**Wooden fronts and wide aluminium frames<sup>1)</sup>**

Lever arm set		X	FAo	Upper front overlay
<input type="checkbox"/>	<input checked="" type="checkbox"/>	mm	SFA	Side front overlay
20L3200.06	21L3200.01	153		
20L3500.06	21L3500.01	203		Wall application: Requires minimum gap 5 mm
20L3800.06	21L3800.01	253		
20L3900.06	21L3900.01	303		

<sup>1)</sup> Use 4 chipboard screws (609.1x00) per side for wooden fronts. Use 4 countersunk self tapping screws (660.0950) per side for wide aluminium frames.

Planning narrow alu frames

**SFA Side front overlay**

For frame frieze width 19 mm: SFA of 11–18 mm possible

\* When changing material thickness, adjust the assembly dimensions accordingly

- Standard
- SERVO-DRIVE





**Front setting**

Lever arm set		a	b*	Max. c
□	■	mm	mm	mm
20L3200.06	21L3200.01	114	257	159
20L3500.06	21L3500.01	146	345	209
20L3800.06	21L3800.01	178	433	259
20L3900.06	21L3900.01	210	522	309.5

\* Dimensions apply to lower gap = 0 mm

**Cornice and crown moulding clearance**

SOB	X
16 mm	28 mm
18 mm	30 mm
19 mm	31 mm

SOB Top panel thickness

**Cross stabiliser**

[1] LW - 129 mm  
SERVO-DRIVE: LW - 164 mm

Connecting piece

[2] Half LW - 147 mm  
SERVO-DRIVE: Half LW - 165 mm

LW Internal width

**SERVO-DRIVE switch**

**Blum distance bumper drilling position**

\* From cabinet front edge for fronts that protrude below the cabinet

Recommendation for aluminium frames: Consider drilling the Blum distance bumper holes in the cabinet side. A trial application must be carried out when fixing the Blum distance bumper to the front.

**i** Do not glue Blum distance bumper.

**Blum distance bumper**



## State-of-the-art stay lifts

**BLUMOTION**  
inside

Compatible with.

**SERVO-DRIVE**  
by Blum

**TIP-ON**  
by Blum

This convenient lift system fitting for mid wall units requires only a small amount of space at the top. The AVENTOS HK stay lift is another product that provides inspiration thanks to its consistently high quality of motion. Handle-less fronts can be opened using SERVO-DRIVE or TIP-ON technology and without any need for hinges.



Watch video of the assembly and adjustment processes



A single touch is all that is needed. The TIP-ON mechanical opening support system makes opening cabinets easier and more convenient than ever before.





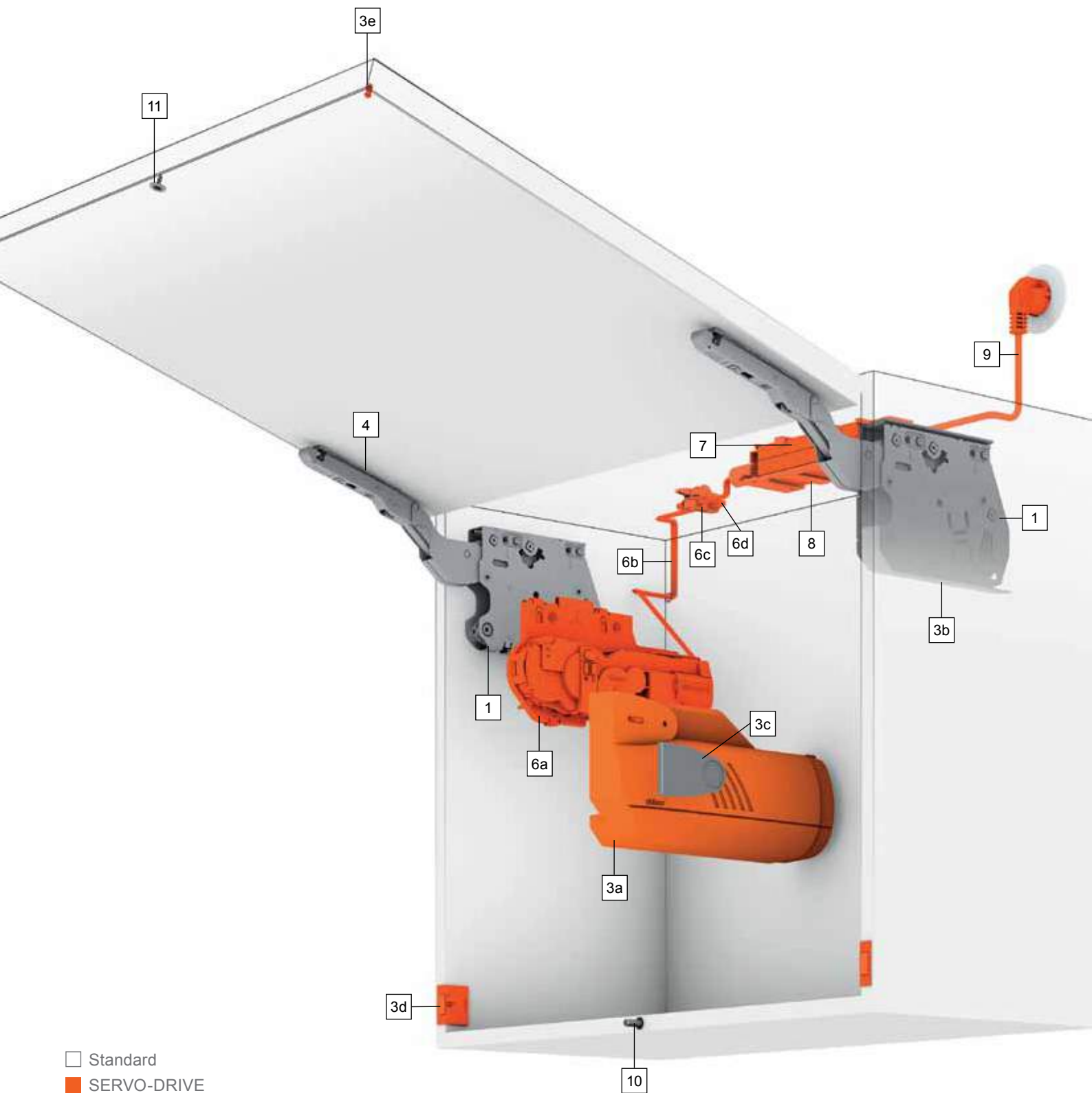

















At the heart of this fitting solution is the lift mechanism with BLUMOTION and a robust spring package.

# AVENTOS HK



- Standard
- SERVO-DRIVE
- TIP-ON



-    **1** Lift mechanism
-    **3a** Cover cap left  
The left SERVO-DRIVE cover cap is used to cover the lift mechanism, drive unit and distribution cable. To cover the cabling, the cover cap can be expanded up to an internal depth of 350 mm.
-    **3b** Cover cap right
-    **3c** Cover cap small
-  **3d** SERVO-DRIVE switch  
The SERVO-DRIVE switch is attached to the cabinet side at the bottom. The switch signals the drive unit via a wireless connection. The 2.4 GHz frequency is certified for international use.
-  **3e** Blum distance bumper  
The Blum distance bumper creates and maintains the required trigger path of 2 mm.
-    **4** Front fixing bracket
-  **6a** Drive unit  
The drive unit is attached without tools to the left lift mechanism. A special drive unit with an adapter plate is required for AVENTOS HK.
-  **6b** Distribution cable  
This cable is used to supply power to the drive unit. The max. permitted operating voltage is 24 V.
-  **6c** Connecting node +  
**6d** cable end protector  
This node establishes the electrical connection between the distribution cable and the transformer. The cable end protector is inserted into the “open” end of the cable.
-  **7** Blum transformer + flex  
**9** The Blum transformer can be used worldwide. It converts the county-specific mains voltage to 24 V direct current. You must use a flex with a regular plug for the respective country depending on the installation location.
-  **8** Transformer unit housing  
The transformer is easily and securely stored in the transformer unit housing.
-  **10** TIP-ON
-  **11** Screw-on catch plate

# Order information

## Standard and SERVO-DRIVE for AVENTOS HK

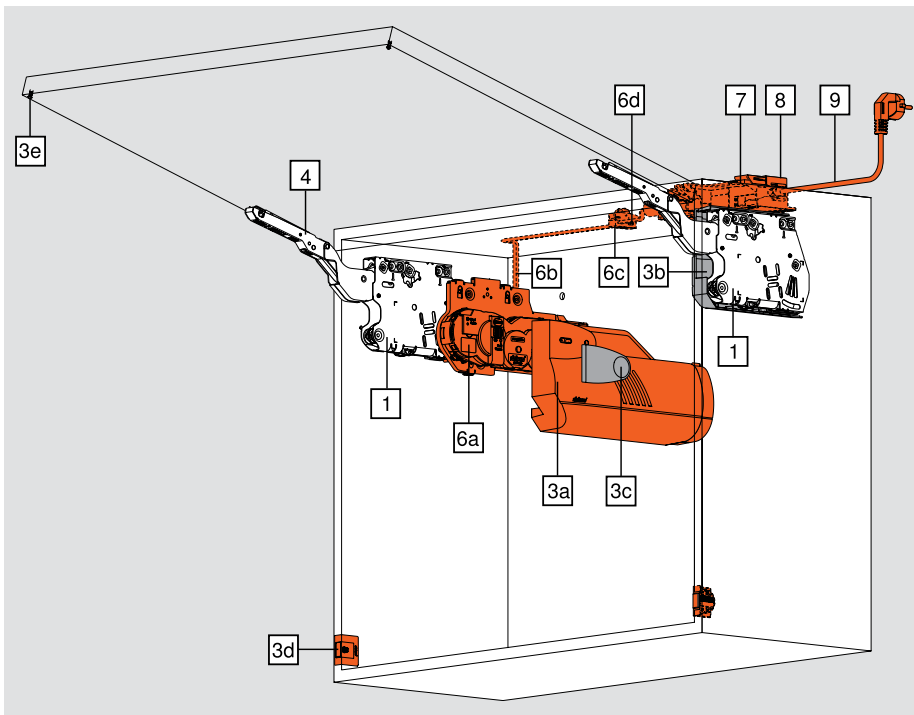

**4 types of lift mechanisms are enough to cover a wide range of applications.**

Using the power factor, you can calculate the number of required lift mechanisms. The power factor required depends on the weight of the front and the cabinet height.

The power factor and the door weight can be increased by 50% when a third lift mechanism is used.

- Standard
- SERVO-DRIVE



Power factor LF = cabinet height KH (mm) x front weight incl. double handle weight (kg)

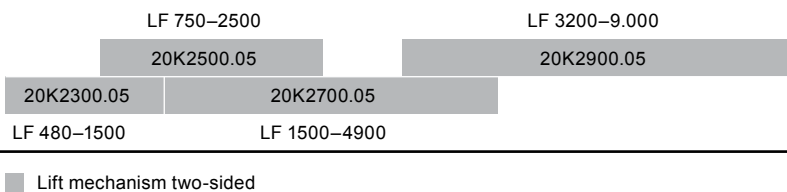



A trial application is recommended when you are in a borderline area of the individual lift mechanism.



	<input checked="" type="checkbox"/> 1	Lift mechanism set		
		Power factor	Opening angle	
		480-1500	107°	20K2300.05
		750-2500	107°	20K2500.05
		1500-4900	107°	20K2700.05
		3200-9000	100° *)	20K2900.05
	<b>Composed of:</b>			
	2 x symmetrical lift mechanisms			
	6 x chipboard screws Ø 4 x 35 mm			
	Max. door weight 18 kg for two lift mechanisms			
	*) Pre-mounted opening angle stop			
	<input type="checkbox"/> 3	Cover cap set		
		Nylon		
		light grey, silk white	20K8000	
		Composed of:		
	3a	1 x cover cap large left		
	3b	1 x cover cap large right		
	3c	2 x cover caps small		



**Note**  
We recommend a lift mechanism attached to the centre panel for wide cabinets. The reason for this is to prevent the middle of the front from sagging when open.

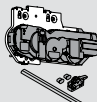



	<b>3</b>	<b>Cover cap set for SERVO-DRIVE</b>	
		Nylon	
		light grey, silk white	<b>21K8000</b>
		Composed of:	
3a		1 x SERVO-DRIVE cover cap large left	
3b		1 x cover cap large right	
3c		2 x cover caps small	
3d		2 x SERVO-DRIVE switches	
3e		4 x Blum distance bumpers, Ø 5 mm	

	<b>5</b>	<b>SERVO-DRIVE set</b>	
		Nylon	
		Dust grey	<b>21KA000</b>
		Composed of:	
6a		1 x drive unit	
6b		1 x distribution cable, 1500 mm	
6c		1 x connecting node	
6d		2 x cable end protectors	
		We recommend two synchronised drive units for a power factor > 9000.	

	<b>4</b>	<b>Front fixing bracket set</b>	
		Nickel plated	
		Wooden fronts and wide aluminium frames <sup>1)</sup>	<b>20S42E1</b>
		Narrow alu frames	<b>20S4200A</b>
		Composed of:	
		2 x symmetrical front fixing brackets	
		<sup>1)</sup> Use 4 chipboard screws (609.1x00) per side for wooden fronts. Use 4 countersunk self tapping screws (660.0950) per side for wide aluminium frames.	

		<b>Opening angle stop</b>	
		Nylon	
		100° Dark grey	2 x <b>20K7041</b>
		75° Dust grey	2 x <b>20K7011</b>

		<b>Bit PZ cross slot</b>	
		Size 2, length 39 mm	
			<b>BIT-PZ KS2</b>

	<b>7, 8, 9</b>	<b>Blum transformer, flex and transformer unit housing</b>	
---	----------------	--	--

# Planning information

## Standard and SERVO-DRIVE for AVENTOS HK

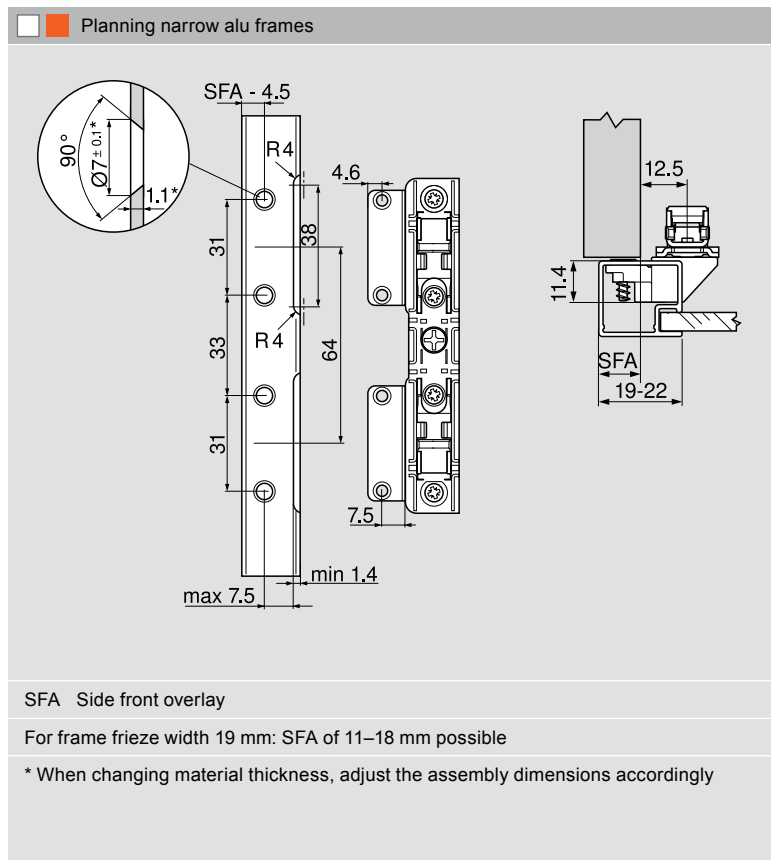
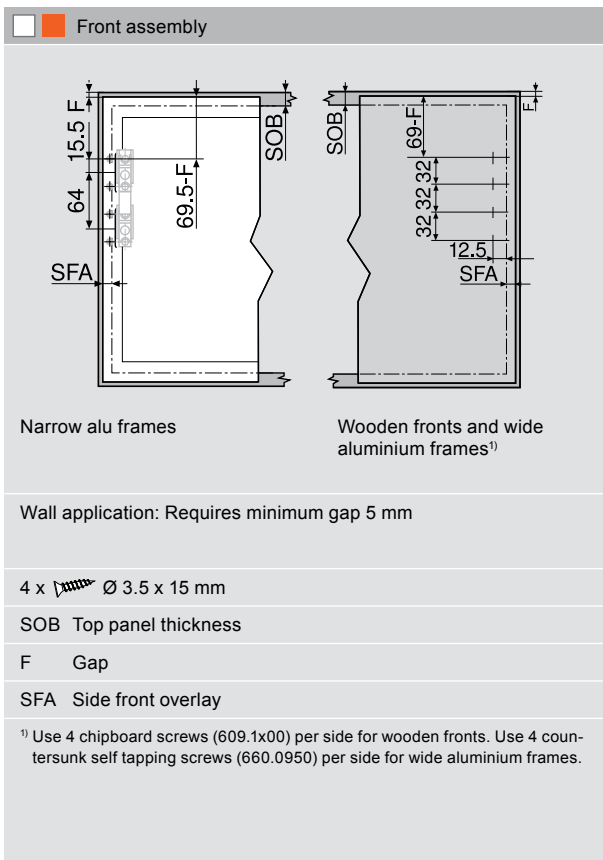
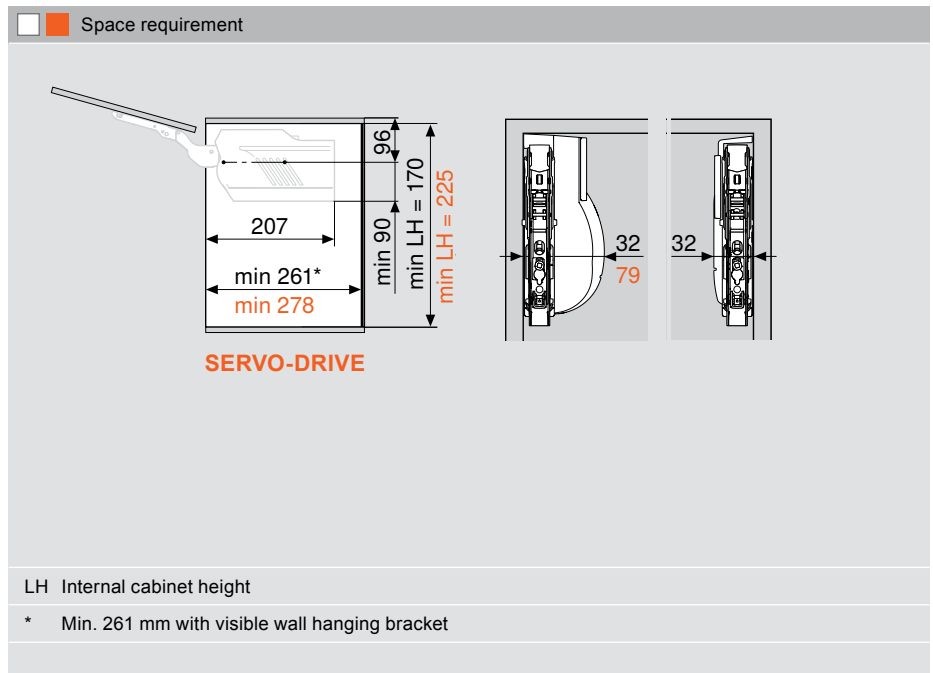
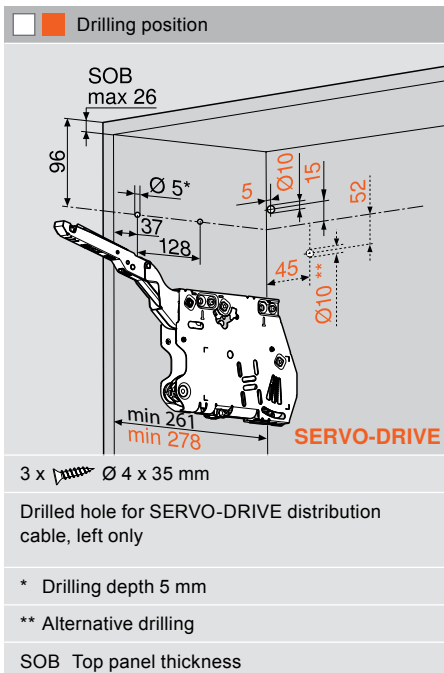

- Standard
- SERVO-DRIVE





**■** Cornice and crown moulding clearance

D (mm)	16	19	22	26	28
X (mm)	70	59	49	35	26

Opening angle stop

Without	$Y = FH \times 0.29 - 15 + D$
100°	$Y = FH \times 0.17 - 15 + D$
75°	$A = FH \times 0.26 + 15 - D$

**■** Minimum gap

MF Minimum gap for opening (2 mm)

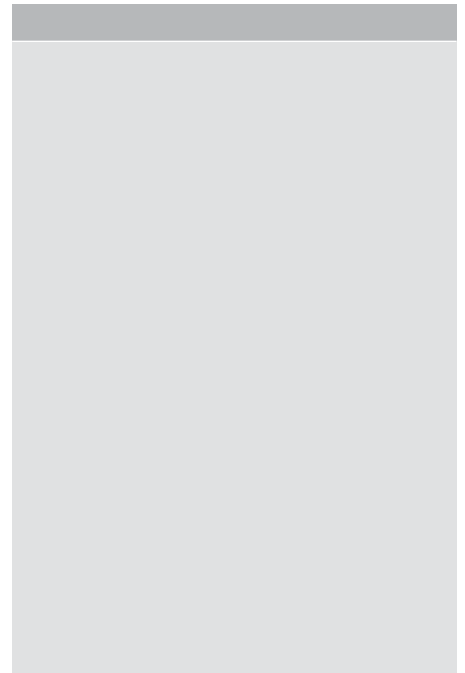

**■** SERVO-DRIVE switch

**■** Blum distance bumper drilling position

In general, we recommend installing 4 distance bumpers near to the switch. For certain applications (high fronts, low weight), 2 distance bumpers may sometimes be sufficient. A trial application is recommended.

Recommendation for aluminium frames: Consider drilling the Blum distance bumper holes in the cabinet side. A trial application must be carried out when fixing the Blum distance bumper to the front.

**i** Do not glue Blum distance bumper.

**■** Blum distance bumper

# Order information

## TIP-ON for AVENTOS HK

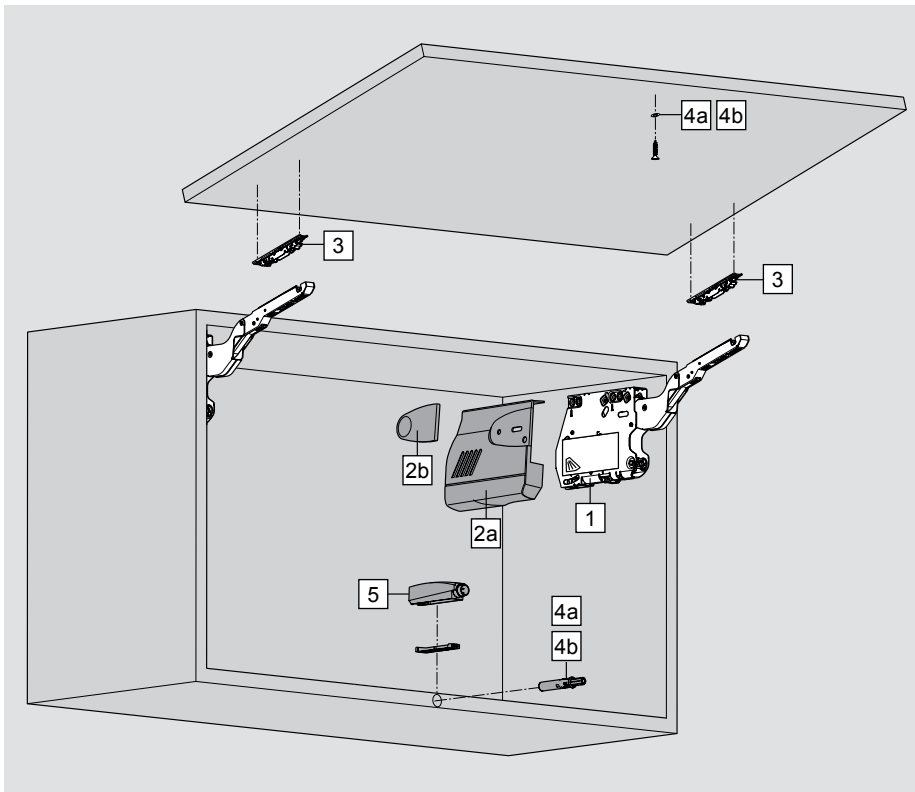

**4 types of lift mechanisms are enough to cover a wide range of applications.**

Using the power factor, you can calculate the number of required lift mechanisms. The power factor required depends on the weight of the front and the cabinet height.

The power factor and the door weight can be increased by 50% when a third lift mechanism is used.

■ TIP-ON



Power factor LF = cabinet height KH (mm) x front weight

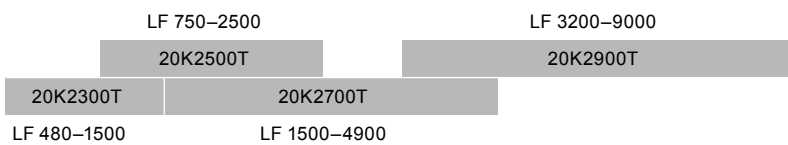

■ Lift mechanism two-sided

LF Power factor

A trial application is recommended when you are in a borderline area of the individual lift mechanism.

	<b>1</b>	<b>Lift mechanism set</b>		
		Power factor	Opening angle	
		480–1500	107°	20K2300T
		750–2500	107°	20K2500T
		1500–4900	107°	20K2700T
		3200–9000	100° *)	20K2900T
		<b>Composed of:</b>		
	2 x symmetrical lift mechanisms			
	6 x chipboard screws Ø 4 x 35 mm			
	Max. door weight 18 kg for two lift mechanisms			
	*) Pre-mounted opening angle stop			
	<b>2</b>	<b>Cover cap set</b>		
		Nylon		
		light grey, silk white		20K8000
		<b>Composed of:</b>		
	2a	1 x cover cap large left		
	2b	1 x cover cap large right		
	2c	2 x cover caps small		
		<b>Opening angle stop</b>		
		Nylon		
		100° Dark grey	2 x	20K7041
		75° Dust grey	2 x	20K7011



	<b>3</b> Front fixing bracket set	
	Nickel plated	
	Wooden fronts and wide aluminium frames <sup>1)</sup>	20S42E1
	Narrow alu frames	20S4200A
	Includes:	
	2 x symmetrical front fixing brackets	
	<sup>1)</sup> Use 4 chipboard screws (609.1x00) for wooden fronts. Use 4 countersunk self tapping screws (660.0950) for wide alu frames.	

	<b>4b</b> TIP-ON long version set	
	For front heights over 500 mm	
	For drilling Ø 10 x 76 mm	
	RAL 7037 nylon, dust grey	
	With magnet	955A1004
	Output path approx. 38 mm	
	Composed of:	
	1 x TIP-ON	
	1 x screw-on catch plate <sup>3)</sup>	
	1 x chipboard screw 609.1500	
	<sup>3)</sup> Note: The glue-on catch plate should not be used in combination with TIP-ON for AVENTOS HK	

	<b>4a</b> TIP-ON set	
	For fronts up to a height of 500 mm	
	For drilling Ø 10 x 50 mm	
	RAL 7037 nylon, dust grey	
	With magnet	955.1004
	Output path approx. 18 mm	
	Composed of:	
	1 x TIP-ON	
	1 x screw-on catch plate <sup>2)</sup>	
	1 x chipboard screw 609.1500	
	<sup>2)</sup> Note: The glue-on catch plate should not be used in combination with TIP-ON for AVENTOS HK	

	<b>5</b> Adapter plate	
	<b>Cruciform adapter plate</b>	
	Nylon 7036 platinum grey	
	Screws	955.1501
	EXPANDO	955.15E1
	Assembly with Ø 3.5 mm or Ø 4 mm chipboard screws	

	<b>Bit PZ cross slot</b>	
	Size 2, length 39 mm	BIT-PZ KS2





**Cornice and crown moulding clearance**

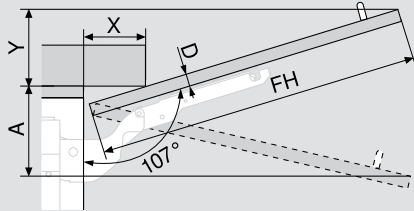

D (mm)	16	19	22	26	28
X (mm)	70	59	49	35	26

**Opening angle stop**

Without	$Y = FH \times 0.29 - 15 + D$
100°	$Y = FH \times 0.17 - 15 + D$
75°	$A = FH \times 0.26 + 15 - D$

**Minimum gap**

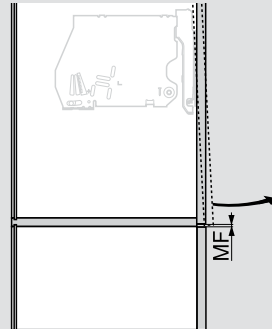

MF Minimum gap for opening (2 mm)

# Planning information

## TIP-ON for AVENTOS HK

### TIP-ON fixing position

Standard version

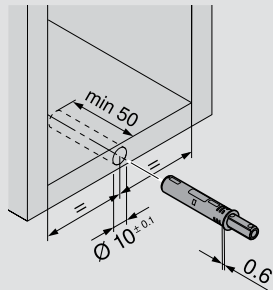

For fronts up to a height of 500 mm

Long version

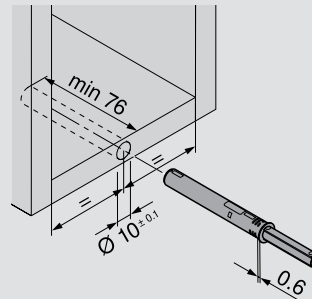

For front heights over 500 mm

### TIP-ON installation dimension

Standard version

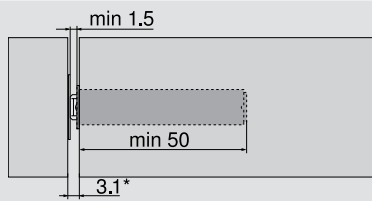

\* Min. 3.1 mm with screw-on catch plate

Long version

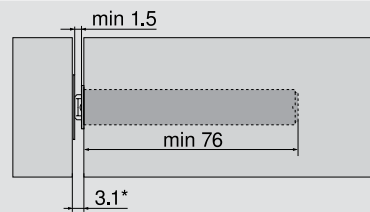

### Adapter plate fixing position

Cruciform adapter plate

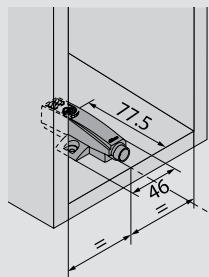

### Adapter plate installation dimension

Cruciform adapter plate

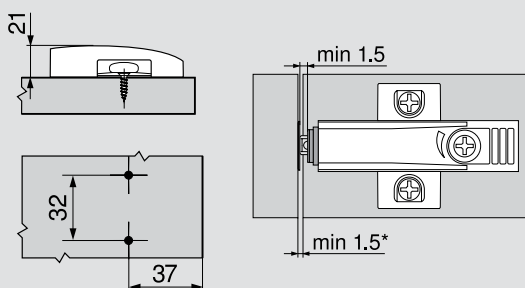

\* Factory setting = 2 mm



### ■ Screw-on catch plate planning

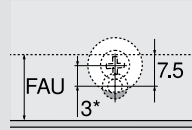
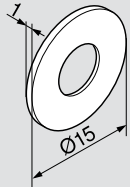

For drilling

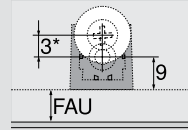

Inline adapter plate

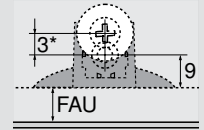

Cruciform adapter plate

\* We recommend offsetting the positioning of TIP-ON by 3 mm for the screw-on catch plate.

Comment: The glue-on catch plate should not be used in combination with TIP-ON for AVENTOS HK

FAU Lower front overlay

### ■ TIP-ON



## Small lift system but supreme ease of motion



AVENTOS HK-S is the perfect choice for small lift systems in tall cabinets, e.g. above refrigerators. Thanks to its neat and tidy dimensions, the fitting can be perfectly integrated into small pieces of furniture, making the best possible use of the storage space.



Watch video of the assembly and adjustment processes





At the heart of this fitting solution is the lift mechanism with BLUMOTION and a robust spring package.

# AVENTOS HK-S

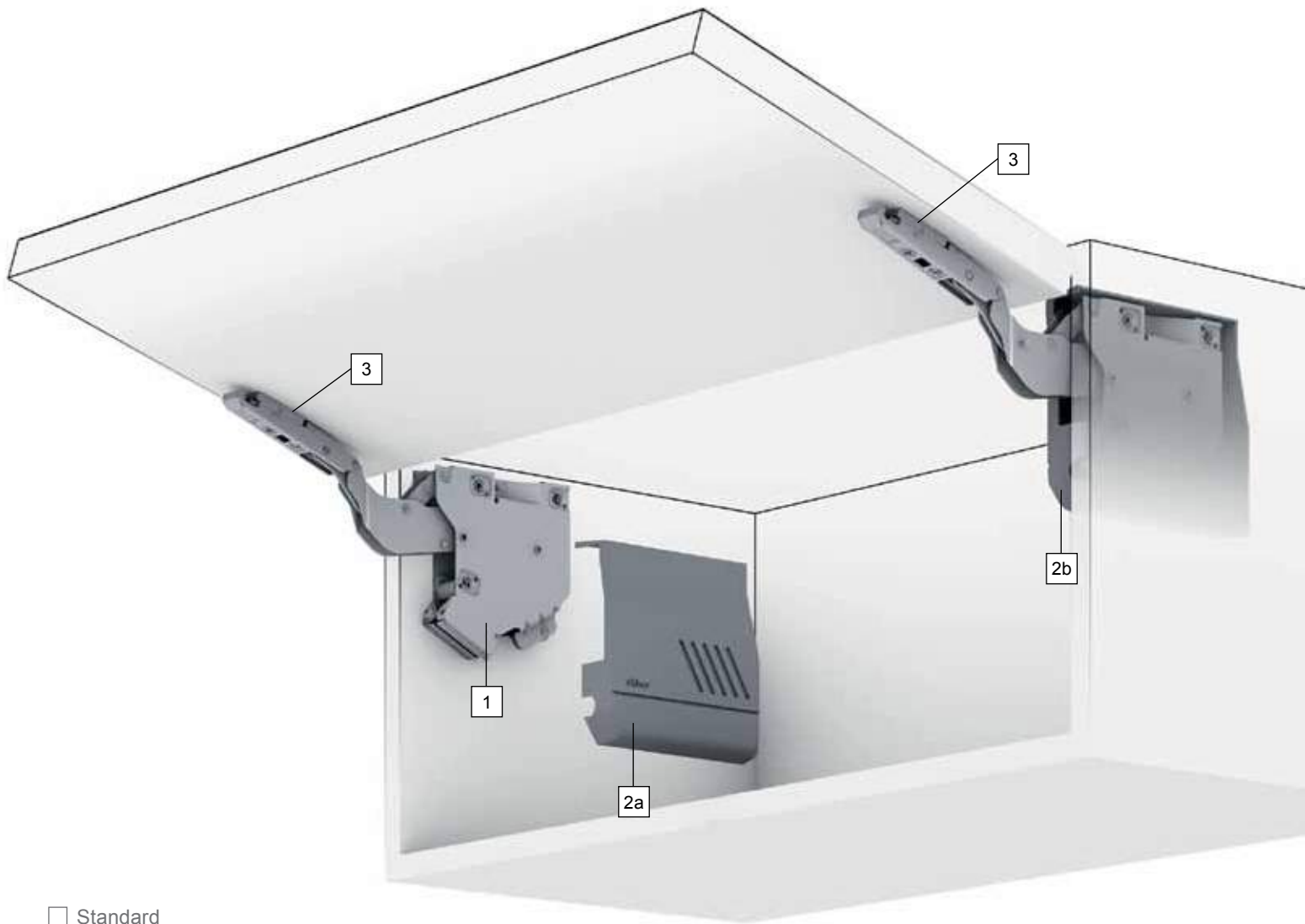

Standard



- 1** Lift mechanism
- 2a** Cover cap, left
- 2b** Cover cap right
- 3** Front fixing bracket

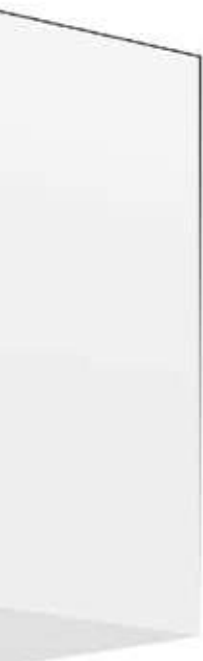

# Order information

## Standard AVENTOS HK-S

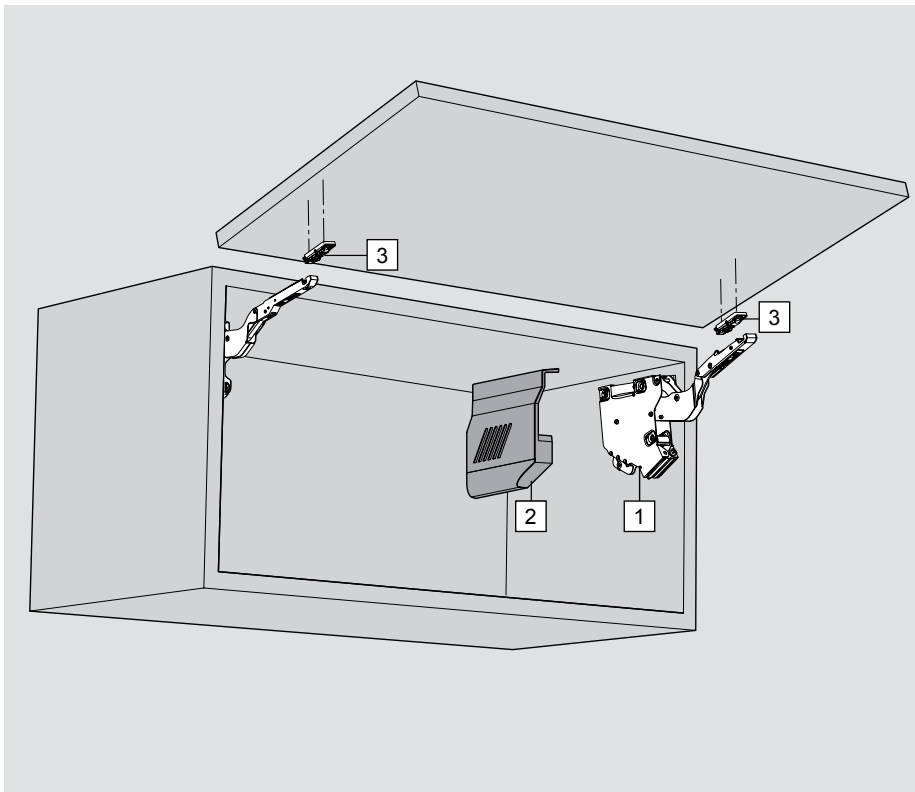

**3 types of lift mechanisms are enough to cover a wide range of applications.**

Using the power factor, you can calculate the number of required lift mechanisms. The power factor required depends on the weight of the front and the cabinet height. The power factor and the door weight can be increased by 50% when a third lift mechanism is used.

The maximum cabinet height for AVENTOS HK-S is 400 mm.

Standard



Power factor LF = cabinet height KH (mm) x front weight incl. double handle weight (kg)

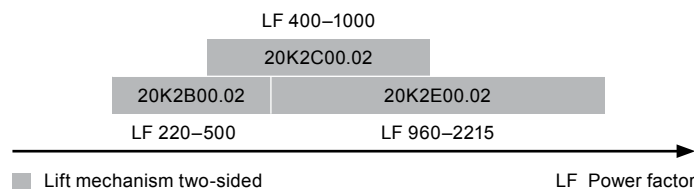



<input type="checkbox"/>	1	Lift mechanism set	
	Power factor	Spring	
	200-500	Weak	20K2B00.02
	400-1000	Medium	20K2C00.02
	960-2215	Strong	20K2E00.02
	Opening angle	107°	
<b>Composed of:</b>			
2 x symmetrical lift mechanisms			
2 x cover caps large left/right light grey, silk white			
6 x chipboard screws, Ø 4 x 35 mm			

<input type="checkbox"/>	3	Front fixing bracket
	Wooden fronts and wide aluminium frames <sup>1)</sup>	2 x 20K42E1.01
	<sup>1)</sup> Use 2 chipboard screws (609.1x00) for wooden fronts. Use 2 countersunk self tapping screws (660.0950) for wide alu frames.	

<input type="checkbox"/>	3	Front fixing bracket set
	Narrow alu frames	20K4A00A01
	<b>Composed of:</b>	
2 x symmetrical front fixing brackets		



<input type="checkbox"/>	Opening angle stop		
	Nylon		
	100° Dark grey	2 x	20K7A41
	75° Dust grey	2 x	20K7A11

<input type="checkbox"/>	Bit PZ cross slot		
	Size 2, length 39 mm		
			BIT-PZ KS2

# Planning information

## Standard AVENTOS HK-S

Drilling position

SOB Top panel thickness

Fixing position

3 x Ø 4 x 35 mm

Space requirement

\* Min. 240 mm with visible wall hanging bracket

Maximum cabinet height 400 mm

Front assembly

Narrow alu frames

Wooden fronts and wide aluminium frames<sup>1)</sup>

Ø 3.5 x 15 mm

SOB Top panel thickness

F Gap

SFA Side front overlay

<sup>1)</sup> Use 2 chipboard screws (609.1x00) for wooden fronts. Use 2 countersunk self tapping screws (660.0950) for wide alu frames.

Planning narrow alu frames

SFA Side front overlay

For frame frieze width 19 mm: SFA of 11–18 mm possible

\* When changing material thickness, adjust the assembly dimensions accordingly

Standard



Cornice and crown moulding clearance

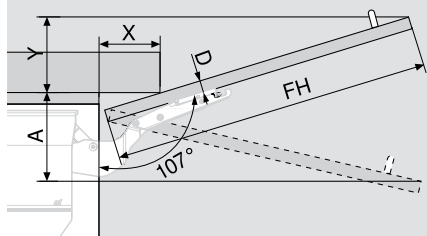

D (mm)	16	19	22	26
X (mm)	70	59	49	35

Opening angle stop	
Without	$Y = FH \times 0.29 - 15 + D$
100°	$Y = FH \times 0.17 - 15 + D$
75°	$A = FH \times 0.26 + 15 - D$

Minimum gap

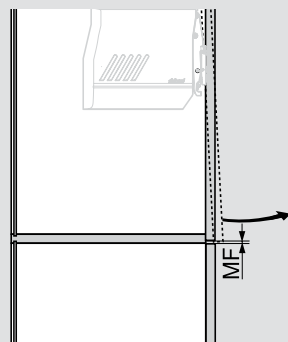

MF Minimum gap for opening (2 mm)

# Order information

## Blum transformer and accessories

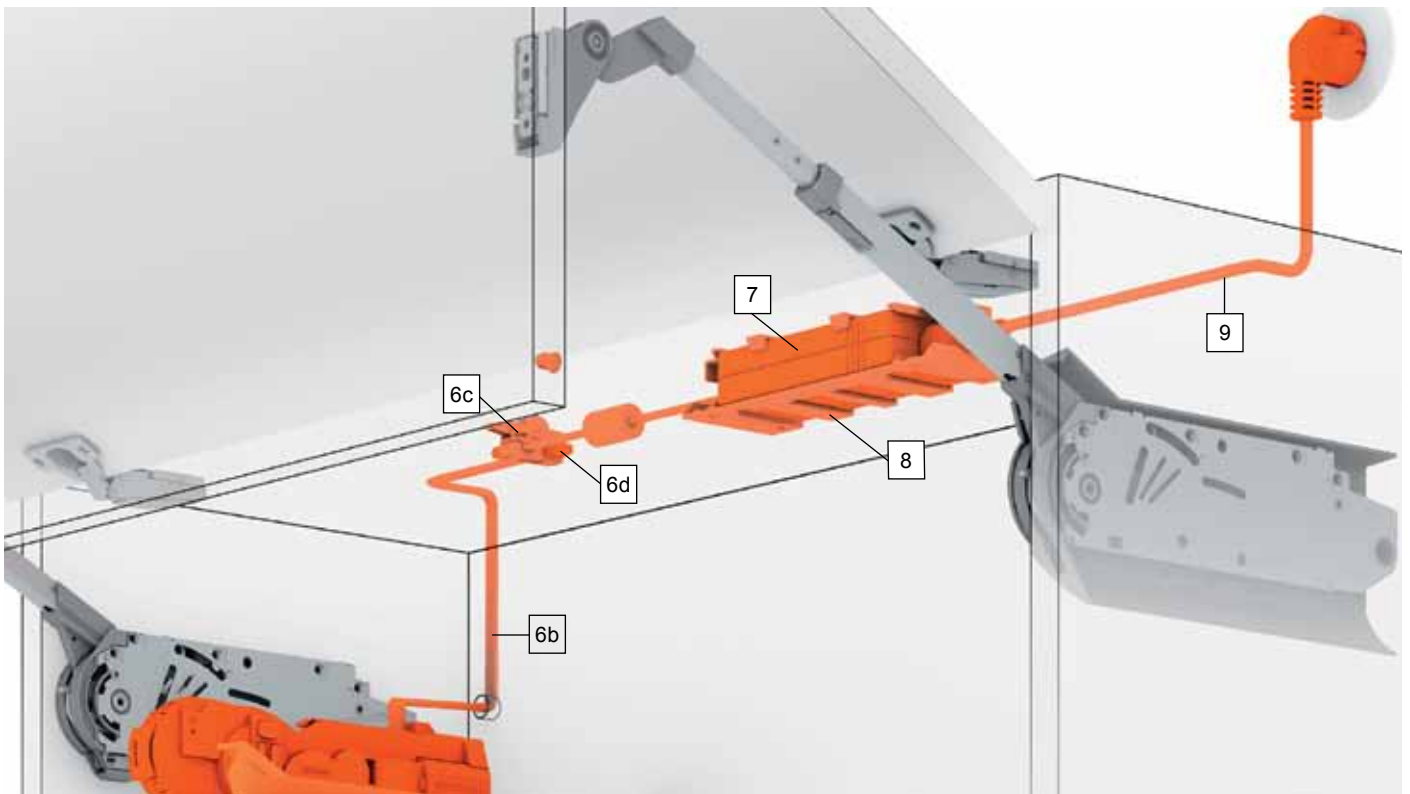

	<b>6c, 6d</b> Connecting node + cable end protector	
	Black	
		Z10V100E.01

	<b>9</b> Flex	
	Flex AU	Z10M200K

	<b>6b, 6d</b> Distribution cable for cutting to size + cable end protector	
	Electrical cable length 8 m with 5 pieces cable end protector	Z10K800AE
	Can be used as a distribution cable	

	<b>Cable holder</b>	
	Using the cable holder, the distribution cable can be easily managed to keep everything tidy and safe.	
	White	Z10K0009

	<b>7</b> Blum transformer	
	72 W	
	Language packages – installation instructions and instruction leaflet	
	D EN, ES, FR, IT, PT	Z10NE020D
	*Note: Blum transformer power consumption on standby is approximately 3.36kWh/a Blum drive unit power consumption on standby is approximately 2.6kWh/a	

	<b>8</b> Transformer unit housing for panel fixing	
	White grey	Z10NG120



# Assembly

## Blum transformer and accessories

### Space requirement and safety distance for Blum transformer unit housing

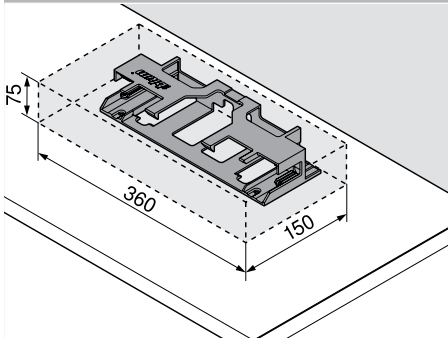

Assembly on the top panel

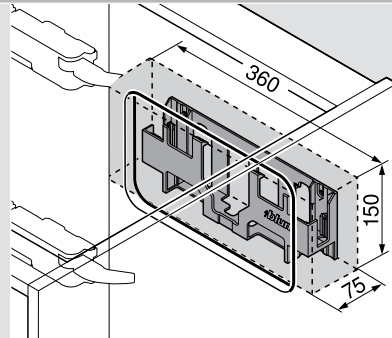

Assembly in combination with SERVO-DRIVE for box and runner systems

**i** A safety distance of 30 mm must be maintained for air circulation (see graphic); otherwise, there is a risk that the Blum transformer could overheat.

### Assembly on the top panel

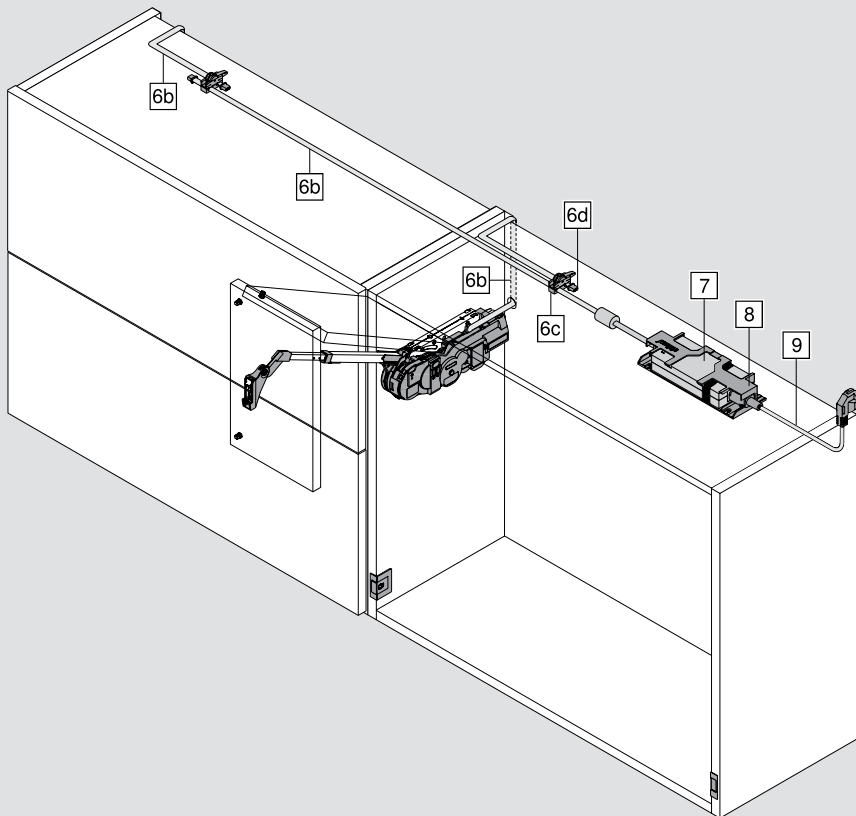

- 6b** Distribution cable for cutting to size
- 6c** Connecting node
- 6d** Cable end protector
- 7** Blum transformer
- 8** Transformer unit housing
- 9** Flex

**i** Only one Blum transformer can be connected to each distribution cable.

### Back cabling

#### Recommended

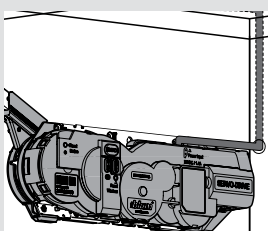

### Upper cabling

#### Optional

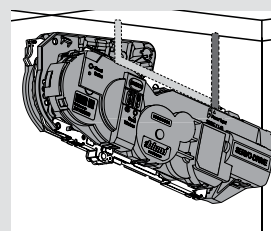

Cabinet front edge to centre of drilled hole

HF: 167 mm

HS: 69 or 167 mm

HL: 74.5 or 167 mm

HK: 167 mm

# Assembly

## Blum transformer and accessories

Cable diagram for two cabinets

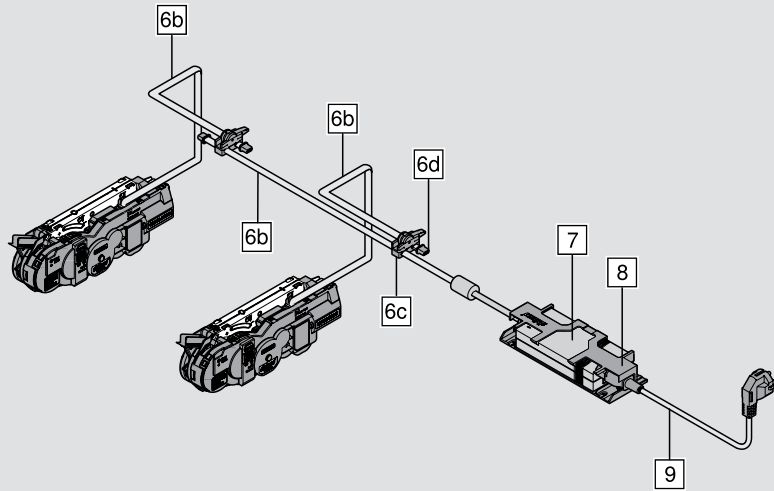

Transformer unit housing

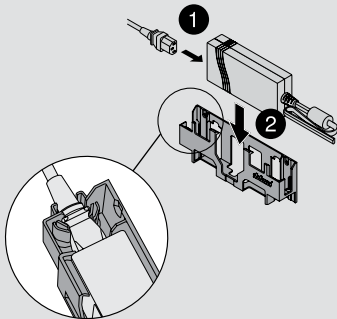

Pull-out stop

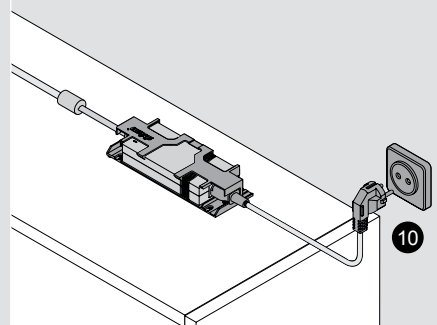
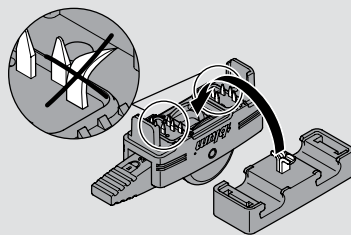
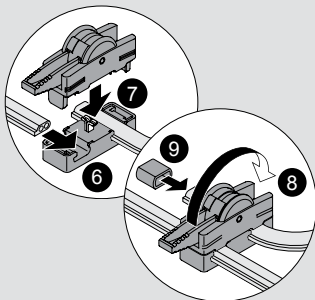
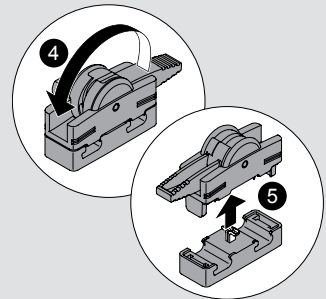
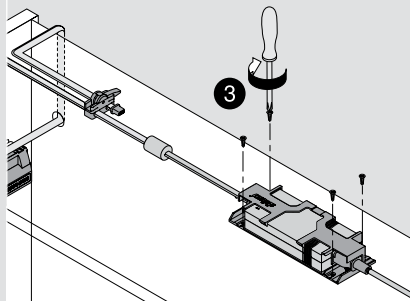

**i** Do not damage piercing pins.

Assembly in combination with SERVO-DRIVE for box and runner systems

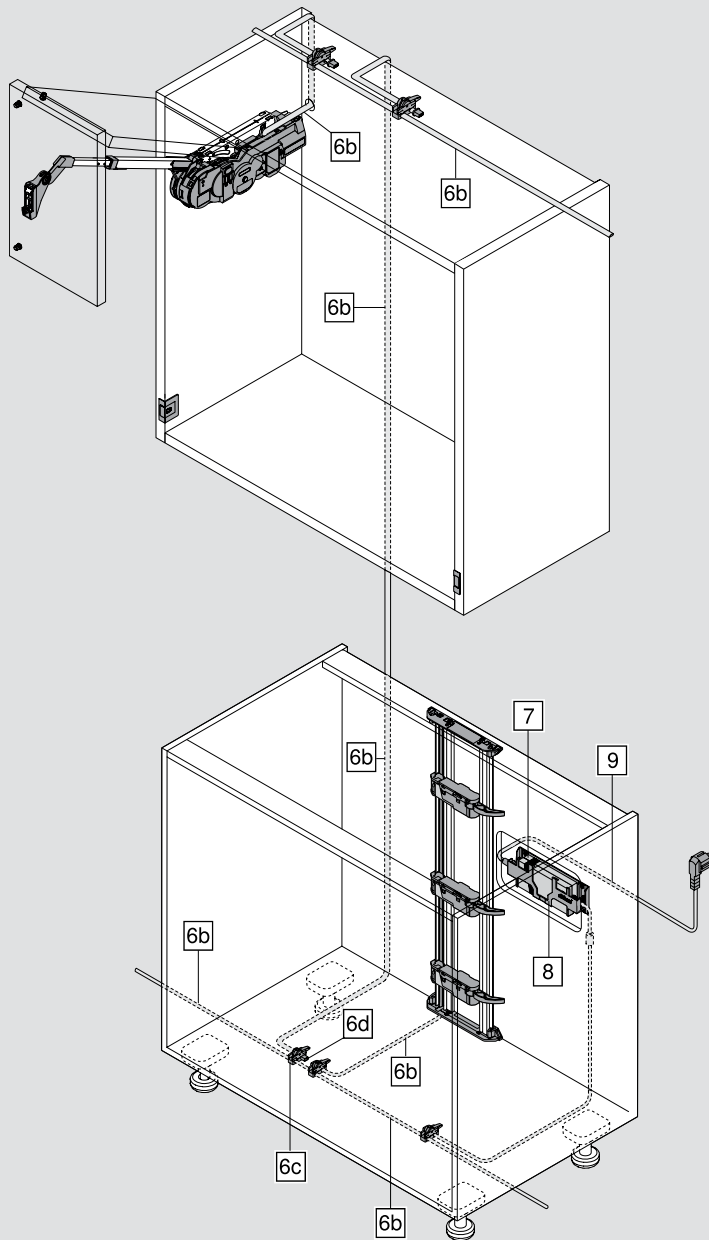

- 6b Distribution cable for cutting to size
- 6c Connecting node
- 6d Cable end protector
- 7 Blum transformer
- 8 Transformer unit housing
- 9 Flex

**i** Only one Blum transformer can be connected to each distribution cable.

# Overview of functions SERVO-DRIVE for AVENTOS

## Start-up

**A** Activating the SERVO-DRIVE switch

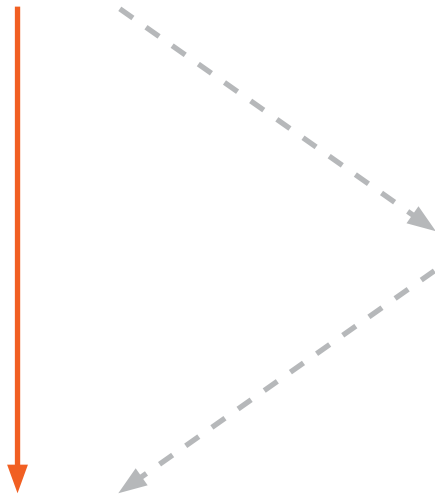

**B** Starting reference run

## Additional features

**C** Activating synchronisation

**D** Activating collision avoidance

Optional

## Deactivation

**E** Reset motion

**F** Reset wireless

## Button layout

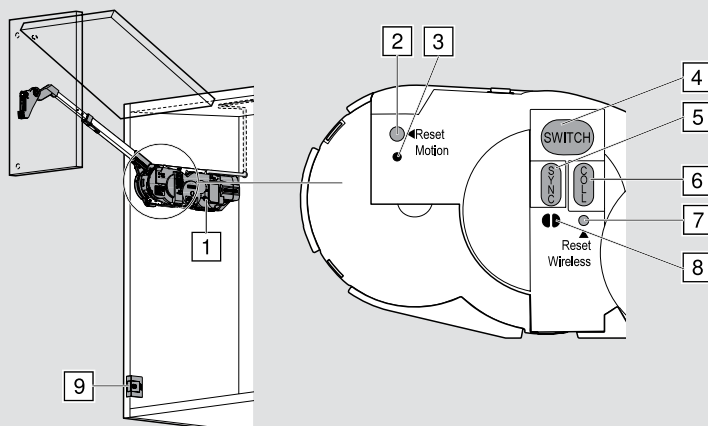

- 1 Drive unit
- 2 <Reset Motion> button
- 3 Motion LED
- 4 <SWITCH> button
- 5 <SYNC> button
- 6 <COLL> button
- 7 <Reset Wireless> button
- 8 Wireless LED
- 9 SERVO-DRIVE switch

# Start-up SERVO-DRIVE for AVENTOS

 Operation

 Lights up continuously

 Flashes

## A Activating the SERVO-DRIVE switch

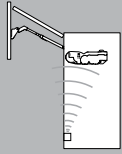

Setting up the wireless connection between the SERVO-DRIVE switch and the drive unit.  
Only one SERVO-DRIVE switch can be assigned to each drive unit.

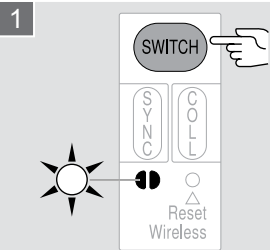

Press the <SWITCH> button until the LED flashes

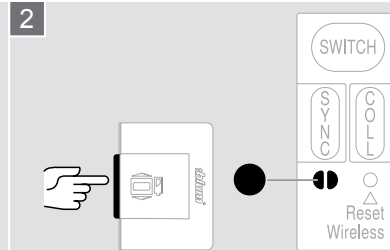

Press the SERVO-DRIVE switch until the LED lights up continuously

3 Repeat procedure A 1–2 for additional SERVO-DRIVE switches in the cabinet.

## Additional features

Optional

C Activating synchronisation

D Activating collision avoidance

## B Starting reference run

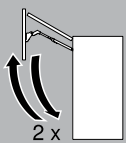

The drive unit recognises the required parameters using the reference run.

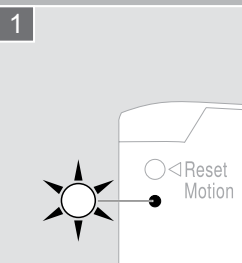

Reference run is required: LED flashes

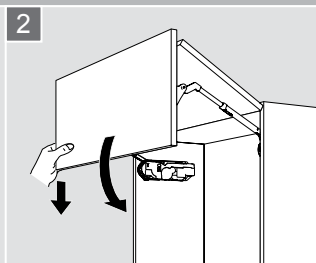

Close the front manually

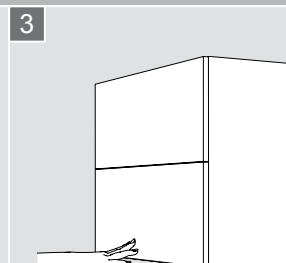

Press on front: The reference run starts automatically

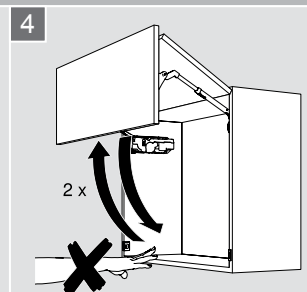

Front opens and closes 2x automatically: Under no circumstances should you try to manually interrupt or stop the process

If the reference run is interrupted, it should be reset – see Reset Motion E 1.  
Restart reference run.

# Additional features SERVO-DRIVE for AVENTOS

 Operation

 Lights up continuously

 Flashes

## C Activating synchronisation

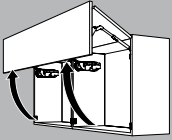

Up to three drive units can be synchronised so that they move simultaneously. This function is required for several cabinets with a uniform front.

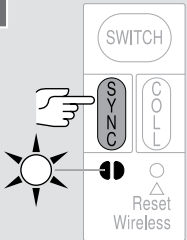
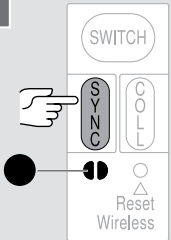
- 1  Press the <SYNC> button on the 1st drive unit until the LED flashes
- 2  Press <SYNC> on the 2nd drive unit until the LEDs on both synchronised drive units light up continuously
- 3 Repeat procedure **C** 1–2 for all additional drive units.

## D Activating collision avoidance

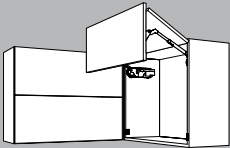

To avoid the collision of fronts, drive units (max. 6) are linked so that only one front can be opened at a time. A front is prevented from opening as long as a linked front remains open.

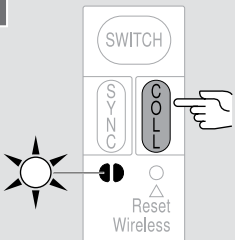
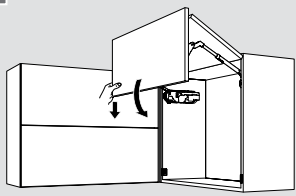
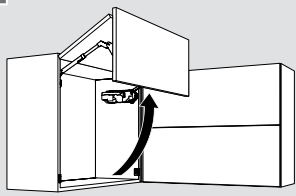
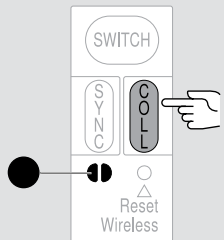
- 1  Press the <COLL> button on the 1st drive unit until the LED flashes
- 2  Close the front manually
- 3  2. Open the front manually
- 4  Press <COLL> on the 2nd drive unit until the LED lights up continuously.
- 5 Repeat procedure **D** 1–4 for all additional cabinets.

# Deactivation SERVO-DRIVE for AVENTOS

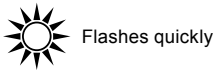

## E Reset motion

Resets the reference run and enables a new reference run to be started.

1

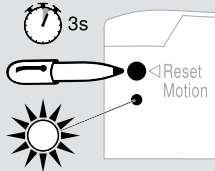

Press the <Reset Motion> button using a pen (at least 3 seconds) until the LED flashes quickly.

## F Reset wireless

Deactivates all functions:  
All active SERVO-DRIVE switches, synchronisations and collision avoidance settings for the respective drive unit are deleted.

1

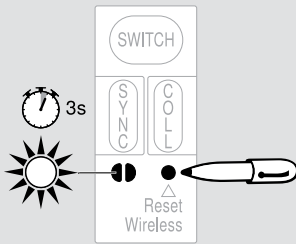

Press the <Reset Wireless> button using a pen (at least 3 seconds) until the LED flashes quickly.

### Motion LED signals

	Flashes orange	Reference run is required
	Lights orange continuously	Power available Operating mode display Reference run successfully completed
	Flashes orange quickly	Reset Motion confirmation

### Wireless LED signals

	Flashes green	Activation mode
	Lights up green continuously	Activation confirmation
	Flashes green quickly	Deactivation confirmation
	Lights red continuously	Last process was not completed successfully



1952



The first product  
Studs are attached to horse-shoes to stop horses slipping.

1958



Début in the furniture industry  
The ANUBA hinge is Blum's first furniture fitting.

1964



Production start  
Blum produces concealed furniture hinges.

1966



Roller runners  
Blum starts to produce roller runners.

1985



Assembly technology  
CLIP hinges can be mounted without tools thanks to CLIP technology.



# Perfecting motion

Blum's fittings solutions are designed to make opening and closing furniture a mesmerising experience. That's why we make every effort to perfect the motion of our lift, hinge, box and runner systems.

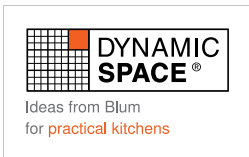

## DYNAMIC SPACE

Blum products help optimise workflows, produce extra storage space and provide enhanced user convenience – making kitchens extremely practical.

## Blum in Austria and around the world

Over 5,000 employees work hard to help us perfect motion. Our fittings are manufactured at ten plants. Seven are in Austria, the remaining are in the USA, Brazil and Poland. Thanks to international subsidiaries and sales agencies, Blum is on site to serve its customers all over the world.

## Global customer benefits

Everyone should benefit from the advantages of Blum products – from furniture manufacturers right down to end users.

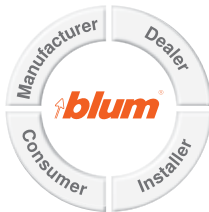

## Top quality

Blum products have been developed for everyday kitchen use and are a pleasure to use a furniture lifetime.



## Innovations

We want our fittings solutions to be innovative and make everyday kitchen use easier. That's why our developments are based on findings from requirement research and input from our customers.

## Environment

Blum strives to minimise its environmental impact. We use environmentally-friendly processes, use raw materials intelligently and save energy wherever we can.



Our commitment to environmental protection is internationally recognised and rewarded. We endeavour to maintain and are always looking to improve our environmental management systems



1987



### BOX systems

Blum's first BOX system goes into production with METABOX.

2001



### Soft-close system

BLUMOTION ensures that furniture closes softly and effortlessly.

2005



### Lift systems

AVENTOS lift systems are presented for the first time

2007



### Electrical opening support system

SERVO-DRIVE has received numerous awards for design and function.

2011

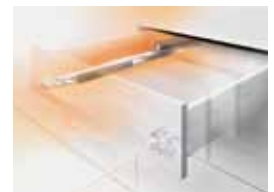

### Runner systems

With MOVENTO, a new generation of runner systems was born.

Experience the mesmerising motion  
Blum showrooms

Sydney (Head Office)  
10 Blackbird Close  
Len Waters Estate NWS 2170  
Ph: 02 9612 5400

Brisbane  
6/39-45 Compton Road  
Underwood QLD 4119  
Ph: 07 3135 9490

Melbourne  
4/245 Ferntree Gully Road  
Mount Waverley VIC 3149  
Ph: 03 9982 1720

Perth  
3/50 Howe Street  
Osborne Park WA 6916  
Ph: 08 6467 0110

Adelaide  
3/277-281 Sir Donald Bradman Drive  
Cowandilla SA 5033  
Ph: 08 8118 6070

All content is copyrighted by Blum.  
Subject to technical modifications and changes to the range without notice.  
Printed in Australia · IDNR: 1,001.39



Blum Australia Pty. Ltd.  
PO Box 1615  
Green Valley, N.S.W 2168  
Toll Free: 1800 179 186  
Fax: +61 2 9822-8540  
E-mail: [info.au@blum.com](mailto:info.au@blum.com)  
[www.blum.com](http://www.blum.com)

The Blum logo, consisting of a stylized arrow pointing upwards and to the right, followed by the word 'blum' in a bold, lowercase, sans-serif font, with a registered trademark symbol (®) to the upper right.